

CORNICI NEW BASIC

2021



Italian Wall Decor
bubolaenaibo.com

BUBOLA & NAIBO

Cornici New Basic

EN Frames New Basic.

Real furnishing elements and not only supports to hang paintings and pictures on the wall. Frames are today an essential element in every home. Walls become herewith full of style, taste and personal emotions.

DE Rahmen New Basic.

Echte Ausstattungselemente und nicht nur Gehäuse die zur Aufhängung von Gemälden und Bildern an die Wand dienen. Die Rahmen sind heutzutage ein essentielles Element in jedem Haus. Die Wände füllen sie sich hiermit von Stil, Geschmack und persönlichen Emotionen.

FR Cadres New Basic.

Les cadres qui décorent les murs de toutes les maisons. De véritables éléments d'ameublement; bien plus que de simples supports pour accrocher des tableaux ou des images au mur, aujourd'hui les cadres sont un élément essentiel dans toutes les maisons. Les murs se remplissent de style, gout et émotions personnelles.

ES Marcos New Basic.

Verdaderos elementos de decoración no son solo un soporte para colgar cuadros y imágenes en las paredes. Los marcos, hoy, son un elemento esencial en cada casa. Las paredes se llenan de estilo, gusto y emociones personales.

Cornici che arredano le pareti di tutte le case.

Elementi d'arredo veri e propri non solo supporti per appendere quadri e immagini ai muri. Le cornici, oggi, sono un elemento essenziale in ogni casa. Le pareti si riempiono di stile, gusto e personali emozioni.

Indice

Index
Inhaltsverzeichnis
Index
Índice

12
Design

24
Natural

40
Colors

46
Country

54
Classic

68
Golden & Silver

84
Minimal

94
Articoli Comple-
mentari
Sundry Articles
Zubehoere
Articles Complémentaires
Complementos de Enmarcación





L'azienda

The company
Das Unternehmen
L'entreprise
La empresa

EN Our company, that was born in 1976 in Soligo (TV) keeps on growing: from a small artisans workshop to the present 14.500 sqm of factory. Thanks to a historical heritage developed giving the right space to innovation, we have joined – with full rights- the interior sector with decorations and wall furnishing.

DE Unser Unternehmen, das 1976 in Soligo (TV) gegründet wurde, expandiert weiter: von einer kleinen Handwerkswerkstatt bis zu den heutigen 14.500 Quadratmetern Fabrik. Dank eines historischen Erbes, das der Innovation den richtigen Raum gibt, haben wir mit vollen Rechten den Bereich der Innenausstattung mit Dekorationen und Wandgestaltung einbezogen.

FR Notre entreprise, née en 1976 à Soligo (TV), continue à croître: d'un petit atelier jusqu'aux établissements actuels de 14.500 m2. Grâce à un patrimoine historique développé en portant l'attention nécessaire à l'innovation, nous sommes entrés de plein pied dans le domaine de « l'intérieur », avec des décorations murales et leurs compléments.

ES Nuestra empresa nació en el 1976 a Soligo (TV) y sigue creciendo: desde pequeño taller hasta los actuales 14.500 mq de instalaciones. La experiencia desarrollada durante tantos años deja lugar a la innovación, accediendo – de pleno derecho – en el sector del interior, con decoraciones y complementos de pared.

Bubola&Naibo.

La nostra azienda, nata nel 1976 a Soligo (TV), continua a crescere: da piccolo laboratorio agli attuali 14.500 mq di stabilimenti. Grazie a un patrimonio storico sviluppato lasciando il giusto spazio all'innovazione, siamo entrati – a pieno titolo – nel settore interior, con decorazioni e complementi da parete.





Le persone.

Fantasia, sensibilità, idee da menti creative, energia, strategia da cuori pulsanti, numeri e visioni, ma anche pezzi, prodotti, pile e stock da mani e gambe che lavorano all'unisono, ognuno dà il suo importante contributo alla realizzazione di qualcosa che funziona solo se tutto l'insieme è coeso e indirizzato allo stesso obiettivo.

EN People.

Fantasy, sensitivity, ideas from creative heads, energy, strategy from beating hearts, numbers and visions, but also pieces, products, piles and stock from hands and legs that work together in unison: everyone gives an important contribution to realise something that works only if the entire group is cohesive and has the same aim.

DE Leute.

Fantasie, Sensibilität, Ideen aus kreativen Geistern, Energie, Strategie aus schlagenden Herzen, Nummer und Visionen, aber auch Stückzahlen, Produkte, Stapel und Warenbestand aus Händen und Beinen die zusammen arbeiten: jeder gibt seinen wichtigen Beitrag um etwas zu realisieren, das nur funktioniert, wenn das Ganze kohärent ist und das gleiche Ziel hat.

FR Les personnes.

Fantaisie, sensibilité, esprits créatifs, énergie, stratégie; les cœurs battent et les idées fusent.

Les chiffres et opinions se mêlent, mains et jambes travaillent ensemble pour produire toujours plus et rester au top sur le marché. Toute le monde apporte sa contribution dans la réalisation de chaque projet. Un ensemble cohésif et dirigé vers un même objectif.

ES Las personas.

Fantasia, sensibilidad, ideas de las mentes creativas, energía, estrategia de corazones palpitantes, números y visiones, el resultado de manos y piernas que trabajan al unísono, cada uno da una importante contribución a la realización de algo que funciona solo si todo el conjunto está unido y dirigido al mismo objetivo.

Certificazioni

Certifications
Zertifizierungen
Certifications
Certificaciones

EN Green Energy.

Our attention to the environment is not only addressed to the rooms and to the interior design products: we have chosen to use green energy, traceable and marked as 100% renewable from the TÜV SÜD certifications – accredited and worldwide well-known mark.

DE Grüne Energie.

Unsere Aufmerksamkeit für die Umwelt gilt nicht nur den Räumen und den Produkten der Innenarchitektur: Wir haben uns für die Verwendung grüner Energie entschieden, die rückverfolgbar ist und durch die TÜV SÜD-Zertifizierungen als 100% erneuerbar gekennzeichnet ist - ein anerkanntes und weltweit bekanntes Zeichen.

FR Energie verte.

Notre attention à l'environnement ne se limite pas aux décors intérieurs et aux compléments d'ameublement. Notre entreprise a choisi de fonctionner à l'énergie verte: une énergie dont l'origine est traçable, attestée renouvelable à 100% par les certifications TUV SUD – label reconnu au niveau international.

ES Energía verde.

Nuestra preocupación por el medio ambiente no se limita al interior y a los complementos de decoración: decidimos utilizar energía verde, renovable al 100% y certificación TUV SUD – etiqueta autorizada y reconocida a nivel internacional.

Energia a tinte green.

La nostra attenzione per l'ambiente non si limita agli interni e ai complementi d'arredo: abbiamo scelto di usare energia verde, rintracciabile e attestata come rinnovabile al 100% dalle certificazioni TÜV SÜD – marchio accreditato e riconosciuto a livello internazionale.





Una cornice per l'ambiente.

Tutto il legno usato per le nostre cornici è certificato FSC[®], una certificazione internazionale di parte terza per i prodotti di derivazione forestale. Gli standard FSC[®] garantiscono una gestione responsabile, che tutela le foreste sotto ogni aspetto: dalla qualità dell'acqua, alla conservazione della copertura forestale.



EN A frame for the environment.

All the wood used for our frames is FSC[®] certified, an international third party certification for the forestry source products. FSC[®] standards guarantee a responsible management, that protect forests under every aspect: from the water quality to the forestry conservation.

DE Einen Rahmen für die Umwelt.

Das gesamte Holz, welches für unsere Rahmen verwendet wird, ist FSC[®] zertifiziert, eine Internationale Drittpartei-Zertifizierung für forstwirtschaftliche Ausgangsprodukte. Die FSC[®] Standards garantieren eine verantwortungsvolle Bewirtschaftung, die die Wälder in jeder Hinsicht schützt: von der Wasserqualität bis hin zur Erhaltung der Wälder.

FR Un cadre pour l'ambiance.

Tout le bois utilisé pour nos cadres est certifié FSC[®], certification internationale concernant les produits d'origine forestière. Le standard FSC[®] garanti une gestion responsable qui protège les forêts sous tous les aspects: de la qualité de l'eau à la conservation de la couverture forestière.

ES Un marco para el medio ambiente.

Toda la madera utilizada en nuestros procesos de producción es certificada FSC[®], una certificación internacional de terceros para los productos de origen forestal. Los standard FSC[®] aseguran una gestión responsable que protege los bosques en todo sus aspectos: desde la calidad del agua a la preservación del desarrollo forestal.

Indice cromatico cornici in legno

Chromatic Index
Farbenindex
Ind x Chromatique
 ndice crom tico

12 BI | p. 20



4405 05 | p. 38



4040 01 | p. 31



6340 08 | p. 30



6110 01 | p. 32



4600 02 | p. 51



3860 12 | p. 43



6110 05 | p. 32



6450 02 | p. 53



5810 01 | p. 18



6370 01 | p. 35



6585 01 | p. 16



6890 01 | p. 42



5790 03 | p. 52



6860 01 | p. 27



6581 01 | p. 48

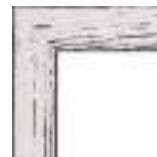

12 AA | p. 20



6570 02 | p. 14



5260 AA | p. 74



6280 02 | p. 72



5780 04 | p. 21



2330 AA | p. 79



5640 AA | p. 75



OVA AA | p. 63



5980 14 | p. 70



4000 07 | p. 81



6875 02 | p. 71

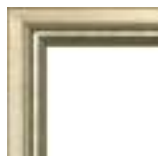

5000 AA | p. 64



6450 AA | p. 78



6585 05 | p. 17



4040 AA | p. 73



6860 05 | p. 27



OVA BI 63 | p. 63



6370 04 | p. 35



6581 03 | p. 48



6440 05 | p. 29

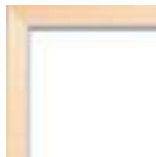

6440 07 | p. 29

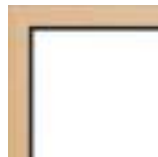

6790 03 | p. 23



5810 06 | p. 18



6585 07 | p. 17



6585 08 | p. 17



6650 07 | p. 56



6370 06 | p. 35



12 NE | p. 20



4405 06 | p. 38



13 NE | p. 36



6340 09 | p. 30



6860 02 | p. 27



6110 09 | p. 33



4600 01 | p. 51



4405 04 | p. 38



4400 04 | p. 39



6110 04 | p. 33



6110 07 | p. 32



3860 14 | p. 58



4310 02 | p. 60



6775 01 | p. 15



4405 03 | p. 38

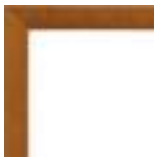

2701 09 | p. 37



4400 03 | p. 39



13 Cl | p. 36



5015 05 | p. 50



3061 MM | p. 61



P15 OO | p. 66



BLU 04 | p. 67



OVA MM | p. 63



13 MM | p. 36



6590 01 | p. 59



6790 01 | p. 23



13 FG | p. 36



4400 01 | p. 39



2701 NA | p. 37



P15 NA | p. 66



6110 03 | p. 33



6340 01 | p. 30



5170 07 | p. 77



5980 12 | p. 70



OVA OO | p. 63



6280 01 | p. 72



6570 01 | p. 14



4310 01 | p. 60



5000 OO | p. 64



6875 01 | p. 71

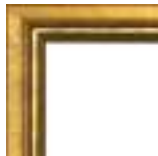

5170 01 | p. 77



4000 01 | p. 81



2490 OO | p. 76



5640 OO | p. 75

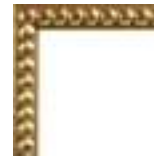

2330 OO | p. 79



2340 OO | p. 80



6450 OO | p. 78



6650 02 | p. 56



6860 06 | p. 26



12 RO | p. 20



5260 14 | p. 44



6550 02 | p. 49



6310 05 | p. 45



6890 02 | p. 42



6310 02 | p. 45



5260 16 | p. 44



5000 04 | p. 65



3860 11 | p. 43



6310 04 | p. 45



5260 20 | p. 44



6890 04 | p. 42



6585 04 | p. 16



5260 07 | p. 44



12 BL | p. 20



6860 04 | p. 26



5015 02 | p. 50



6550 04 | p. 49



6440 04 | p. 28



6440 03 | p. 28



6310 03 | p. 45



6860 03 | p. 26



5000 03 | p. 65



3860 10 | p. 43



6890 03 | p. 42



12 VE | p. 20



Design

Laddove la luce sposa la forma nasce l'idea di design: linee semplici e d'impatto che danno forza e carattere all'ambiente.

EN Design

Where the light meets the shape, the idea of design comes up: simple lines but with a strength that gives power and personality to the room.

DE Design

Wo die Licht die Form trifft, dort kommt die Idee des Design ans Leben: einfache und wirkungsvolle Linien die Stärke und Charakter an dem Raum geben.

FR Design

Là où la lumière épouse la forme naît l'idée de design: des lignes simples qui donnent force et caractère à l'ambiance.

ES Design

Allí donde la luz se mezcla con la forma, nace la idea del diseño: líneas simples y de impacto que dan fuerza y carácter al ambiente.





Serie: **Dune**

Art.: 6570



			
Size	Min. Qty	Size	Min. Qty
10x15	2	21x29,7	2
13x18	2	24x30	2
15x20	2	30x40	2
18x24	2	29,7x42	1
		30x45	1
		40x50	1
		50x60	1
		50x70	1
		60x80	1



Cod. Col. 6570/01



Cod. Col. 6570/02

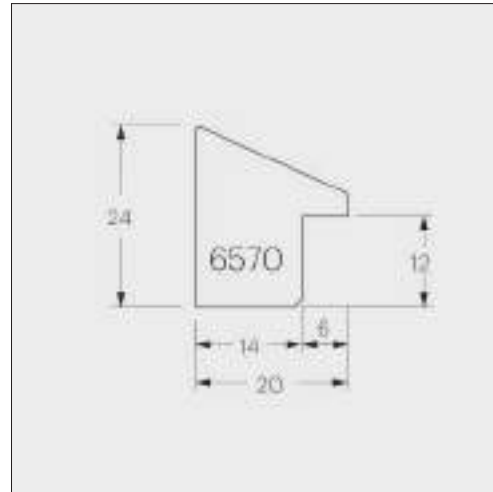

Serie: **Ruden**

Art.: 6775



Size	Min. Q.ty	Size	Min. Q.ty
10x15	2	21x29,7	2
13x18	2	24x30	2
15x20	2	30x40	2
18x24	2	29,7x42	2
		30x45	2
		35x50	2
		40x50	2
		50x60	2
		50x70	2



Cod. Col. 6775/01

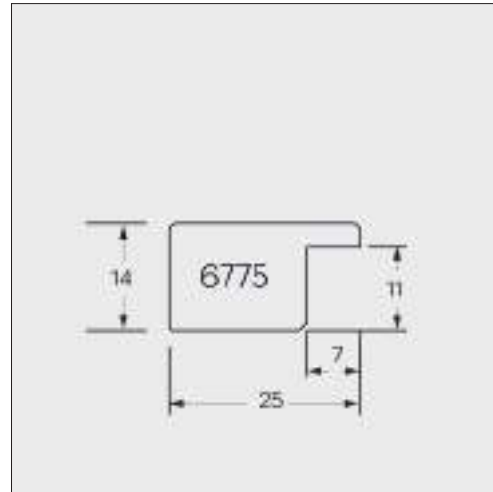

Serie: **Svea**

Art.: 6585



Size		Min. Q.ty		Size		Min. Q.ty	
10x15	2	21x29.7	2				
13x18	2	24x30	2				
15x20	2	25x35	2				
18x24	2	30x40	2				
		40x50	2				
		50x70	2				
		60x80	2				



Cod. Col. 6585/01



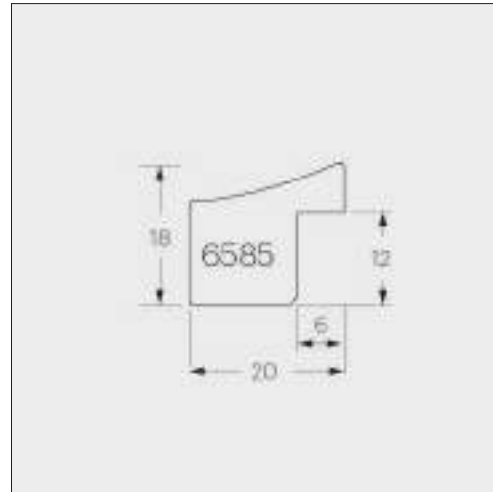

Cod. Col. 6585/04



Serie: **Svea**

Art.: 6585



			
Size	Min. Q.ty	Size	Min. Q.ty
10x15	2	21x29.7	2
13x18	2	24x30	2
15x20	2	25x35	2
18x24	2	30x40	2
		40x50	2
		50x70	2
		60x80	2



Cod. Col. 6585/05



Cod. Col. 6585/08



Cod. Col. 6585/07

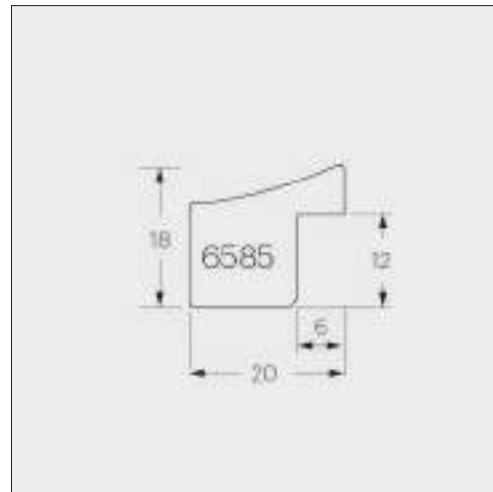

Serie: **Lela**

Art.: 5810



Size		Min. Q.ty		Size		Min. Q.ty	
10x15	2	21x29.7	2	30x40	2	35x50	1
13x18	2	24x30	2	40x50	1	50x70	1
18x24	2	25x35	2				



Cod. Col. 5810/01



Cod. Col. 5810/06

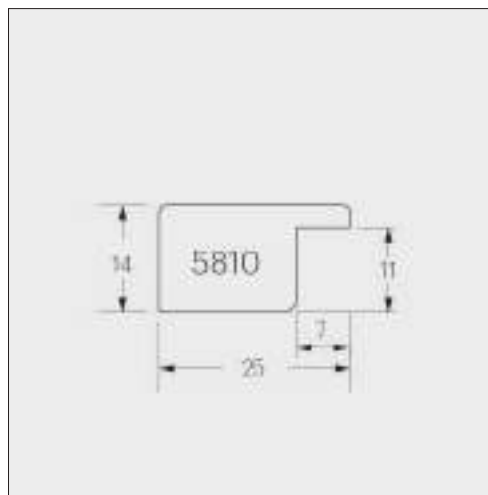



Serie: **Frank**

Art.: 12



Size		Min. Qty		Size		Min. Qty	
10x15	2	25x35	2				
13x18	2	30x30	2				
		30x40	2				
		29,7x42	2				
		30x45	2				
18x24	2	35x50	2				
20x30	2	40x50	2				
21x29,7	2	50x70	2				
24x30	2	60x80*	2				
		70x100*	2				
		PLEXI*					



Cod. Col. 12/NE



Cod. Col. 12/BI



Cod. Col. 12/RO



Cod. Col. 12/AA



Cod. Col. 12/BL



Cod. Col. 12/VE

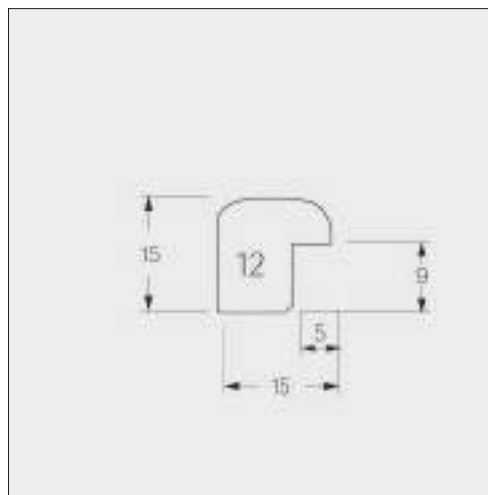

Serie: Nathalie

Art.: 5780



Size	Min. Q.ty	Size	Min. Q.ty
10x15	2	21x29.7	2
13x18	2	24x30	2
18x24	2	30x40	2
		40x50	2
		50x70	2
		60x80	1



Cod. Col. 5780/04

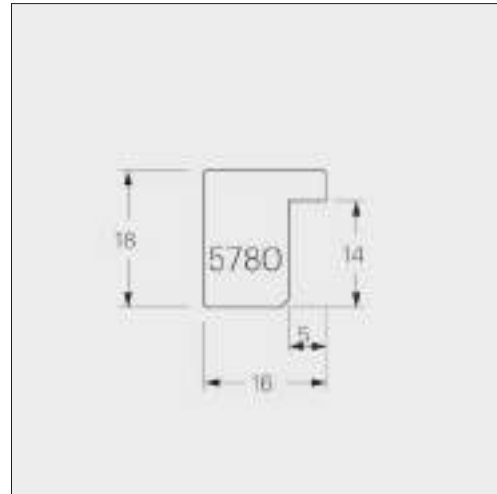



Serie: **Unika**

Art.: 6790



Size	Min. Q.ty	Size	Min. Q.ty
10x15	2	21x29.7	2
13x18	2	24x30	2
15x20	2	25x35	2
18x24	2	30x40	2
		35x50	2
		40x50	2
		40x60	2



Cod. Col. 6790/01

Cod. Col. 6790/03

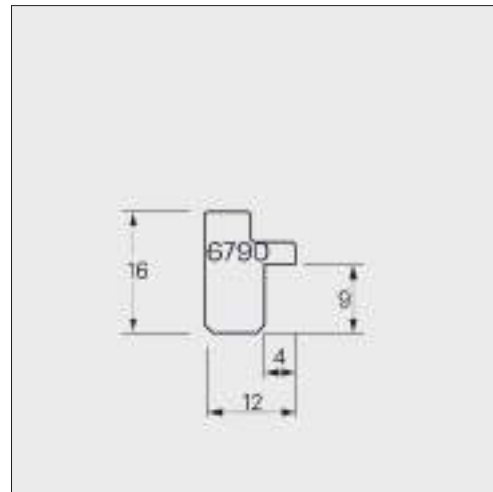

Natural

Natural è lo stile semplice, genuino, neutro rispetto a mode e tendenze, quello che si fa notare per la sua bellezza ma non ruba l'occhio ad altri elementi.

EN Natural

Natural is the simple, genuine, neutral style compared to fashion and tendencies, the one that draws attention through its beauty but does not steal the view of other elements.

DE Natural

Natural ist der einfache, authentische und neutrale Stil im Vergleich zu Mode und Tendenzen, derjenige der für seine Schönheit bemerkt wird aber keine Sicht an anderen Sachen steht.

FR Natural

Le style Naturel est le style simple, authentique et neutre par rapport aux modes et tendances; une beauté sobre et discrète qui met le tableau en valeur.

ES Natural

Natural es el estilo simple, genuino, permanece ajeno a modas y tendencias. Se hace notar por su belleza sin restar protagonismo a otros elementos.





Serie: **Tosca**

Art.: 6860



Size		Min. Q.ty		Size		Min. Q.ty	
10x15	2	21x29.7	2				
13x18	2	24x30	2				
18x24	2	25x35	2				
		30x40	2				
		40x50	2				
		50x70	2				



Cod. Col. 6860/06



Cod. Col. 6860/03



Cod. Col. 6860/04

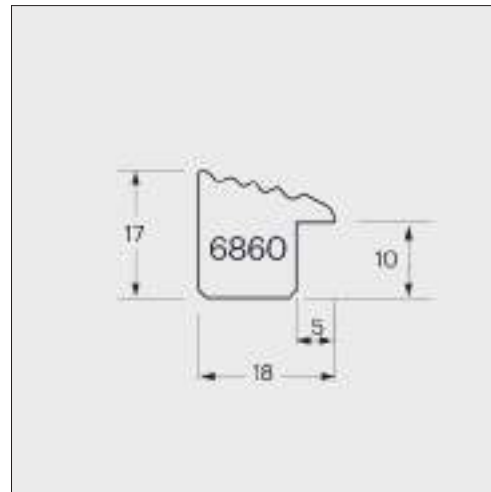

Serie: **Tosca**

Art.: 6860



Size		Min. Q.ty		Size		Min. Q.ty	
10x15	2	21x29.7	2	13x18	2	24x30	2
18x24	2	25x35	2	30x40	2	40x50	2
		50x70	2				



Cod. Col. 6860/02

Cod. Col. 6860/05

Cod. Col. 6860/01

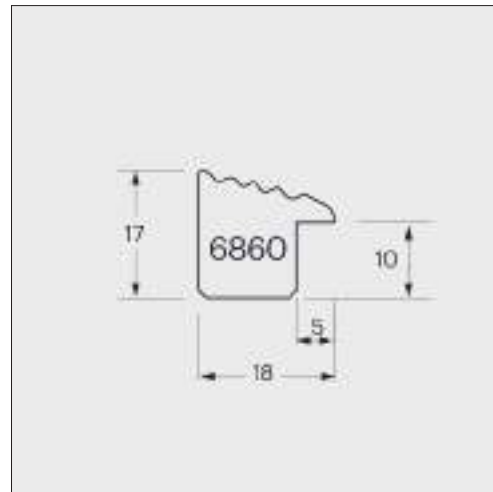

Serie: **Carina**

Art.: 6440



Size	Min. Qty	Size	Min. Qty

10x15	2	21x29,7	2
13x18	2	24x30	2
15x20	2	25x35	2
18x24	2	30x40	2



Cod. Col. 6440/03



Cod. Col. 6440/04

			30x45	2
			35x50	1
			40x50	1
			50x70	1
Size	Ppt Size	Min. Qty		
20x20	14x14	2		
30x30	20x20	2		

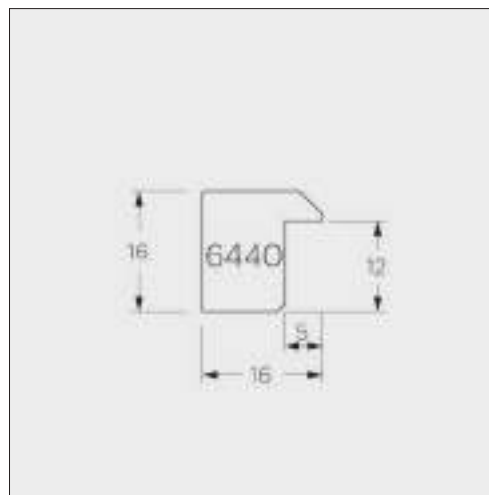

Serie: **Carina**

Art.: 6440



Size	Min. Qty	Size	Min. Qty

10x15	2	21x29.7	2
13x18	2	24x30	2
15x20	2	25x35	2
18x24	2	30x40	2



		30x45	2
		35x50	1
		40x50	1
		50x70	1

Size	Ppt Size	Min. Qty
20x20	14x14	2
30x30	20x20	2



Cod. Col. 6440/05



Cod. Col. 6440/07

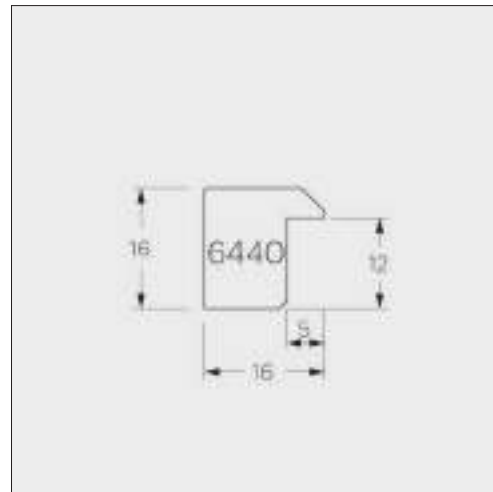

Serie: **Tulipa**

Art.: 6340



Size		Min. Qty	
10x15	2	21x29,7	2
13x18	2	24x30	2
15x20	2	25x35	2
18x24	2	30x40	2
		29,7x42	2
		35x50	2
		40x50	2
		40x60	2
		50x60	2
		50x70	2
		60x80	2



Cod. Col. 6340/09



Cod. Col. 6340/08



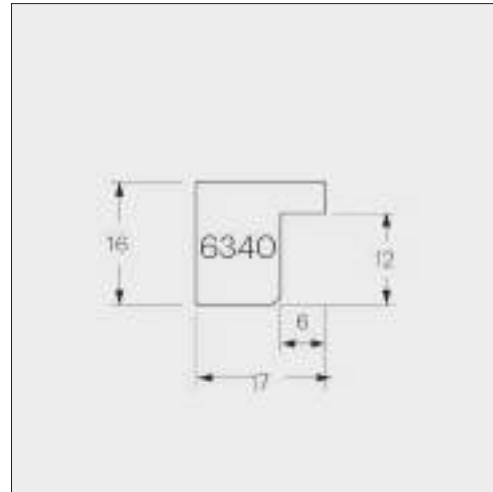

Cod. Col. 6340/01



Serie: **James**

Art.: 4040



			
Size	Min. Q.ty	Size	Min. Q.ty
10x15	2	21x29,7	2
13x18	2	24x30	2
18x24	2	25x35	2
		30x40	2
		40x40	2
		35x50	2
		40x50	2
		50x50	2
		50x70	2



Cod. Col. 4040/01

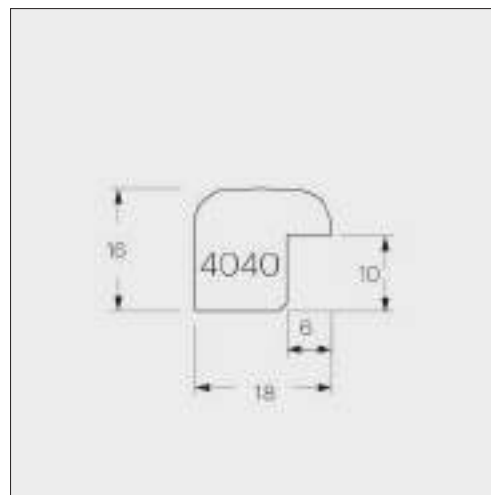



Serie: Sandra

Art.: 6110



Size		Min. Qty	Size		Min. Qty
10x15		2	21x29,7		2
13x18		2	24x30		2
18x24		2	25x35		2
			30x40		2
			35x50		2
			40x50		2
Size	Ppt Size	Min. Qty	50x70		2
20x20	14x14	2	60x80		2
30x30	20x20	2	61x91,5*		1
PLEXI*					

-  Cod. Col. 6110/01
-  Cod. Col. 6110/05
-  Cod. Col. 6110/07

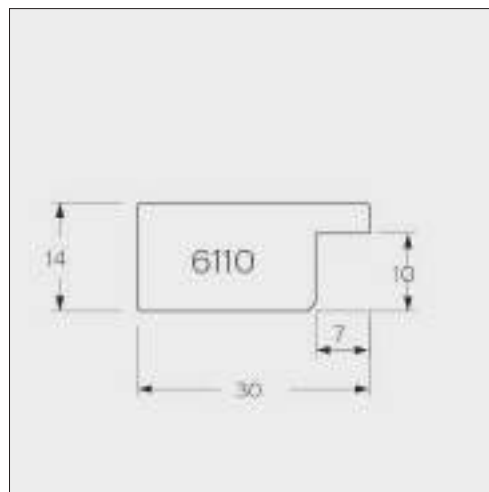

Serie: **Sandra**

Art.: 6110



Size		Min. Qty	Size		Min. Qty
10x15		2	21x29,7		2
13x18		2	24x30		2
18x24		2	25x35		2
			30x40		2
			35x50		2
			40x50		2
			50x70		2
Size	Ppt Size	Min. Qty			
20x20	14x14	2	60x80		2
30x30	20x20	2	61x91,5*		1
			PLEX*1		



Cod. Col. 6110/03



Cod. Col. 6110/04



Cod. Col. 6110/09

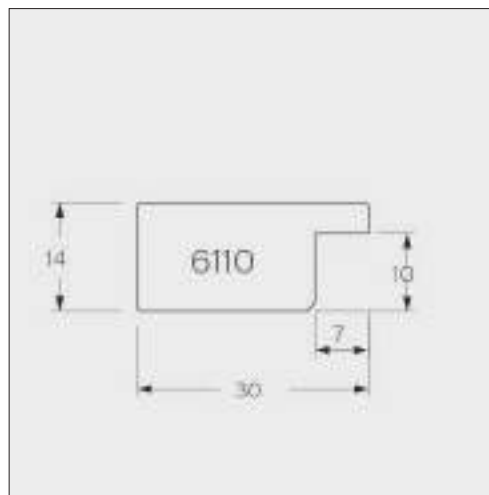





Serie: **Marie Claire**

Art.: 6370



			
Size	Min. Q.ty	Size	Min. Q.ty
10x15	2	21x29,7	2
13x18	2	24x30	2
15x20	2	30x40	2
18x24	2	29,7x42	2
		30x45	2
		35x50	2
		40x50	2
		40x60	2
		50x70	2



Cod. Col. 6370/01



Cod. Col. 6370/04



Cod. Col. 6370/06

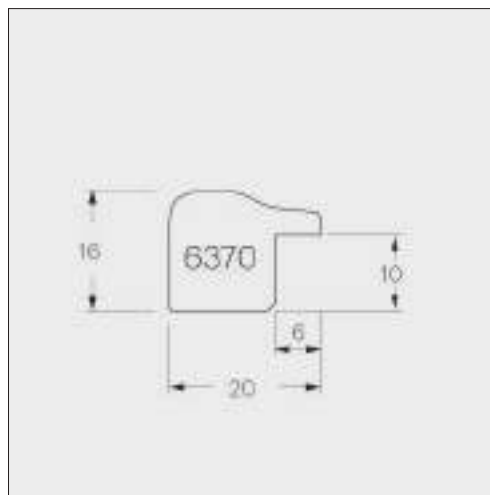

Serie: **Eva**

Art.: 13



Size	Min. Qty	Size	Min. Qty
10x15	2	20x30	2
13x18	2	21x29.7	2
18x24	2	24x30	2
		25x35	2
		30x40	2
		29,7x42	2
		30x45	2
		40x50	2
		50x60	2
		50x70	2



Cod. Col. 13/NE



Cod. Col. 13/FG



Cod. Col. 13/CI



Cod. Col. 13/MM

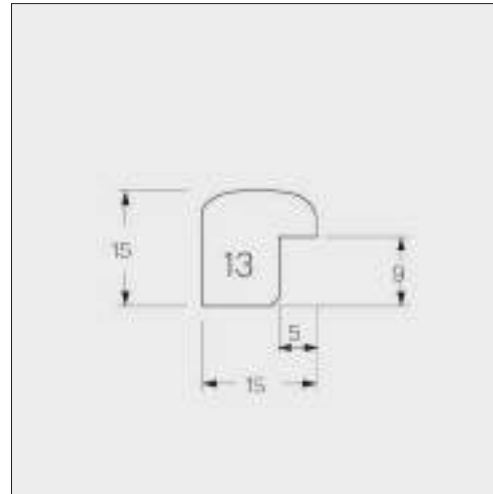

Serie: **Giulia**

Art.: 2701



Size	Min. Q.ty	Size	Min. Q.ty
10x15	2	20x30	2
13x18	2	21x29.7	2
18x24	2	24x30	2
		25x35	2
		29.7x42	2
		30x40	2
		30x45	2
		40x50	2
		50x70	2



Cod. Col. 2701/09



Cod. Col. 2701/NA

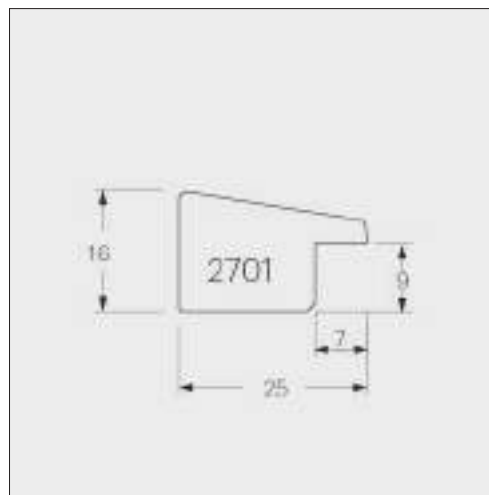





Serie: **Brooke**

Art.: 4405



Size		Min. Q.ty		Size		Min. Q.ty	
10x15	2	21x29.7	2				
13x18	2	24x30	2				
18x24	2	25x35	2				
		30x40	2				
		29,7x42	2				
		35x50	2				
Size	Ppt Size	Min. Q.ty					
20x20	14x14	2	40x50	2			
30x30	20x20	2	40x60	2			
50x50	40x40	2	50x70	2			
			60x80	1			

-  Cod. Col. 4405/03
-  Cod. Col. 4405/04
-  Cod. Col. 4405/05
-  Cod. Col. 4405/06

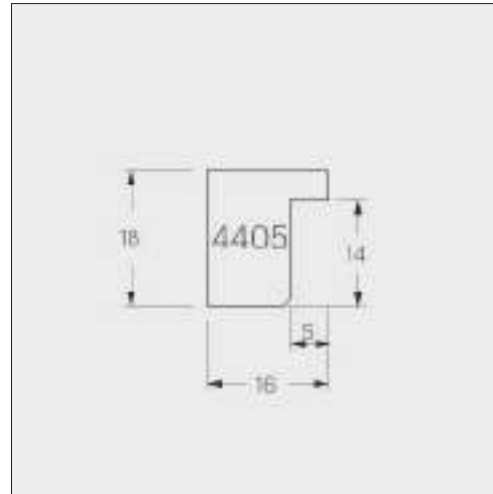

Serie: **Polly**

Art.: 4400

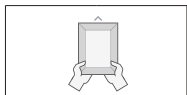

Size	Min. Q.ty
10x15	2
13x18	2
18x24	2
21x29,7	2
24x30	2
25x35	2
30x40	2
40x50	2
50x70	2
60x80	1



Cod. Col. 4400/01



Cod. Col. 4400/03



Cod. Col. 4400/04

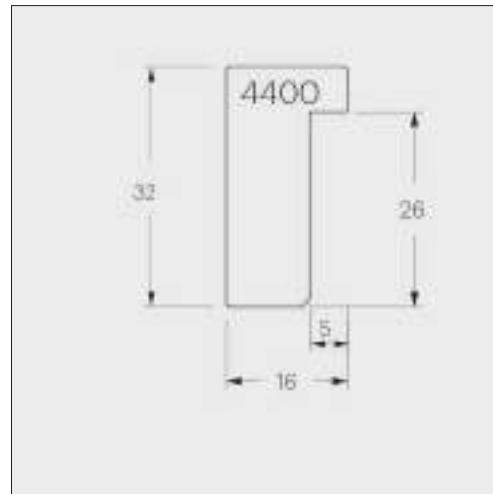

Colors

I colori sono vita,
i colori sono arte,
i colori sono natura,
non priviamo le
nostre case di gioia
e allegria, di musica
e colori.

EN Colors

Colours are life, colours are art, colours are nature. Do not deprive your house of happiness and cheerfulness, of music and colours.

DE Colors

Die Farben sind Leben, die Farben sind Kunst, die Farben sind Natur. Berauben Sie Ihren Häuser der Freude und des Glücks, der Musik und der Farben nicht.

FR Colors

Les couleurs sont « vie ». Les couleurs sont « nature ». Nous ne privons nos maisons ni de joie ni de bonheur, ni de musique ni des couleurs.

ES Colors

Los colores son vida, los colores son arte, los colores son naturaleza, no privamos nuestras casas de júbilo y alegría, de música y colores.









Serie: **Vera**

Art.: 6890



Size	Min. Qty	Size	Min. Qty
10x15	2	21x29,7	2
13x18	2	24x30	2
18x24	2	25x35	2
		30x40	2
		40x50	2
		50x70	2
		60x80	2

-  Cod. Col. 6890/01
-  Cod. Col. 6890/02
-  Cod. Col. 6890/03
-  Cod. Col. 6890/04

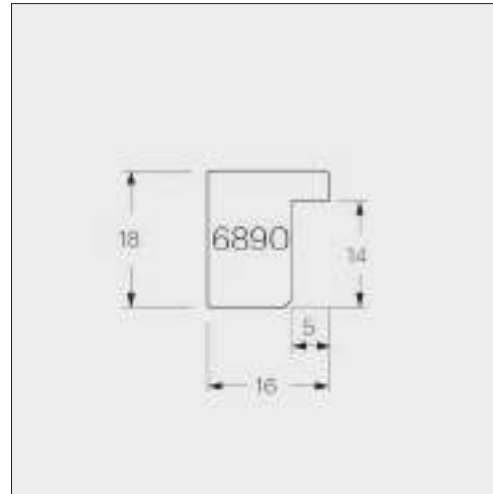

Serie: **Andy**

Art.: 3860-3840



Size	Min. Q.ty	Size	Min. Q.ty
10x15	2	21x29.7	2
13x18	2	24x30	2
18x24	2	25x35	2
		30x40	2
		35x50	2
3840			
		40x50	1
		50x60	1
		50x70	1
		60x80	1

- 3860/12
- Cod. Col. 3840/12
- 3860/10
- Cod. Col. 3840/10
- 3860/11
- Cod. Col. 3840/11

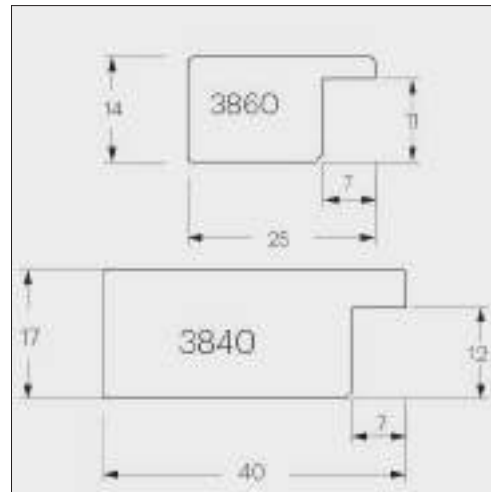





Serie: **Vince**

Art.: 5260



Size		Min. Q.ty		Size		Min. Q.ty	
10x15	2	20x30	2				
13x18	2	21x29.7	2				
15x20	2	24x30	2				
18x24	2	25x35	2				
		30x40	2				
		30x45	2				
		35x50	2				
		40x50	2				
		50x70	2				

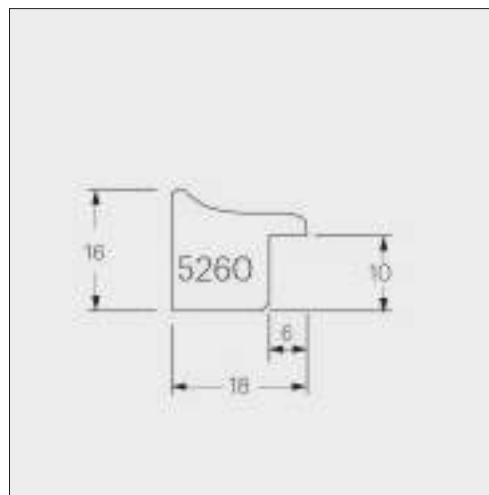

-  Cod. Col. 5260/20
-  Cod. Col. 5260/07
-  Cod. Col. 5260/16
-  Cod. Col. 5260/14



Serie: **Marisol**

Art.: 6310



			
Size	Min. Q.ty	Size	Min. Q.ty
10x15	2	21x29,7	2
13x18	2	24x30	2
15x20	2	25x35	2
18x24	2	30x40	2
		29,7x42	2
		35x50	2
		40x50	2
		50x70	2



Cod. Col. 6310/05



Cod. Col. 6310/02



Cod. Col. 6310/03



Cod. Col. 6310/04

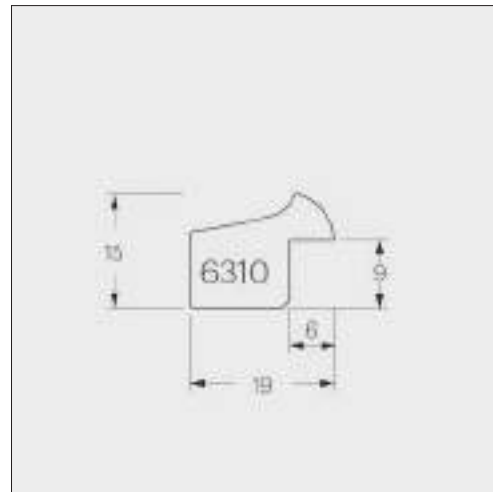

Country

Calde atmosfere,
profumo di ambra
e brioches appena
sfornate, erba bagnata
e rugiada cristallina,
queste sono emozioni
country.

EN Country

Warm atmospheres, scent of amber and smell of fresh baked croissants, wet grass and crystal clear dew: these are country emotions.

DE Country

Warme Atmosphäre, Bernstein Duft und Duft von frisch gebackenen Croissants, nasses Gras und kristalliner Tau: diese sind Country Emotionen.

FR Country

Des ambiances chaudes: parfum d'ambre et de croissants tout juste sortis du four, de l'herbe humide et de rosée cristalline; ce sont des émotions «country».

ES Country

Ambientes cálidos, perfume de ámbar y croissants recién horneados, hierba mojada y rocío cristalino, estas son las emociones country.







Serie: **Athina**

Art.: 6581



			
Size	Min. Q.ty	Size	Min. Q.ty
10x15	2	20x30	2
13x18	2	21x29.7	2
15x20	2	24x30	2
18x24	2	25x35	2
		30x40	2
		30x45	2
		35x50	2
		40x50	2
		50x70	2



Cod. Col. 6581/01



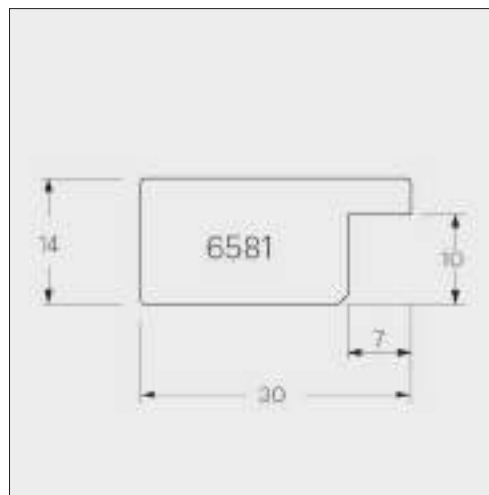

Cod. Col. 6581/03



Serie: **Soledad**

Art.: 6550



			
Size	Min. Q.ty	Size	Min. Q.ty
10x15	2	20x30	2
13x18	2	21x29.7	2
15x20	2	24x30	2
18x24	2	25x35	2
		30x40	2
		30x45	2
		35x50	2
		40x50	2
		50x70	2



Cod. Col. 6550/02



Cod. Col. 6550/04

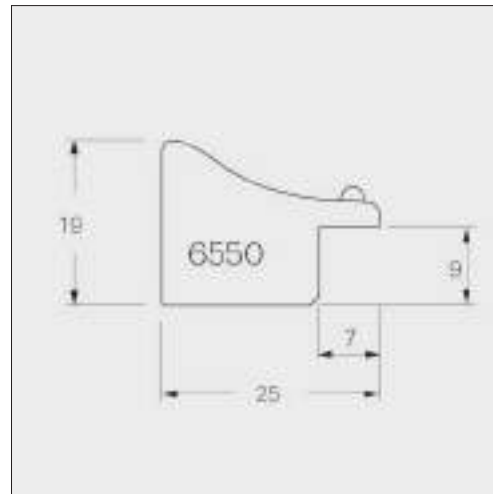

Serie: **Fabriano**

Art.: 5015



Cod. Col. 5015/02



Cod. Col. 5015/05

Size	Min. Q.ty	Size	Min. Q.ty
10x15	2	20x20	2
13x18	2	20x30	2
15x20	2	21x29,7	2
18x24	2	24x30	2

25x35	2		
29,7x42	2		
30x30	2		
30x40	2		
30x45	2	50x70	2
35x50	2	60x80	2
40x50	2	61x91,5	2
50x60	2	70x100	2

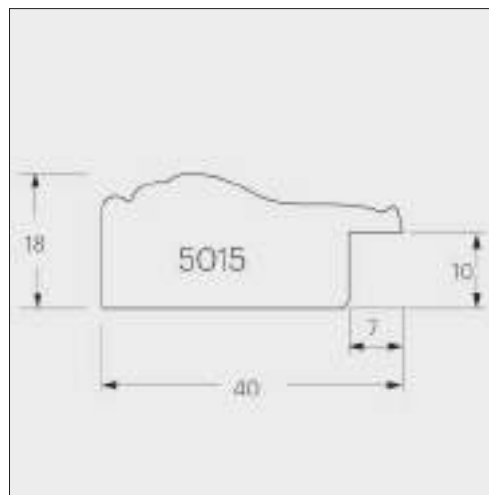

Serie: **Raia**

Art.: 4600

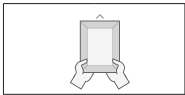

Size	Min. Q.ty
------	-----------

13x18	2
18x24	2
20x30	2
25x35	2
30x40	2
40x50	2
50x70	2
60x80	1
70x100	1



Cod. Col. 4600/01



Cod. Col. 4600/02

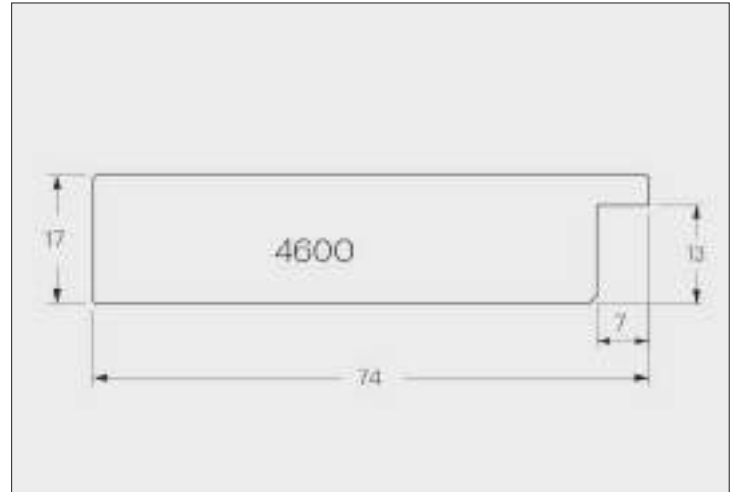

Serie: **Milton**

Art.: 5790



Size	Min. Q.ty	Size	Min. Q.ty
10x15	2	20x20	2
13x18	2	20x30	2
15x20	2	21x29.7	2
18x24	2	24x30	2
		25x35	2
		30x30	2
		30x40	2
		30x45	2
		35x50	2
		40x50	2
		50x70	2



Cod. Col. 5790/03

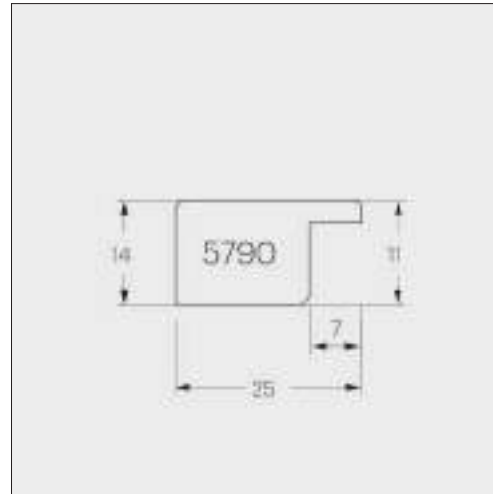

Serie: **Amber**

Art.: 6450



			
Size	Min. Q.ty	Size	Min. Q.ty
10x15	2	21x29.7	2
13x18	2	24x30	2
15x20	2	25x35	2
18x24	2	30x40	2
		30x45	2
		35x50	2
		40x50	2
		50x70	2
		60x80	1



Cod. Col. 6450/02

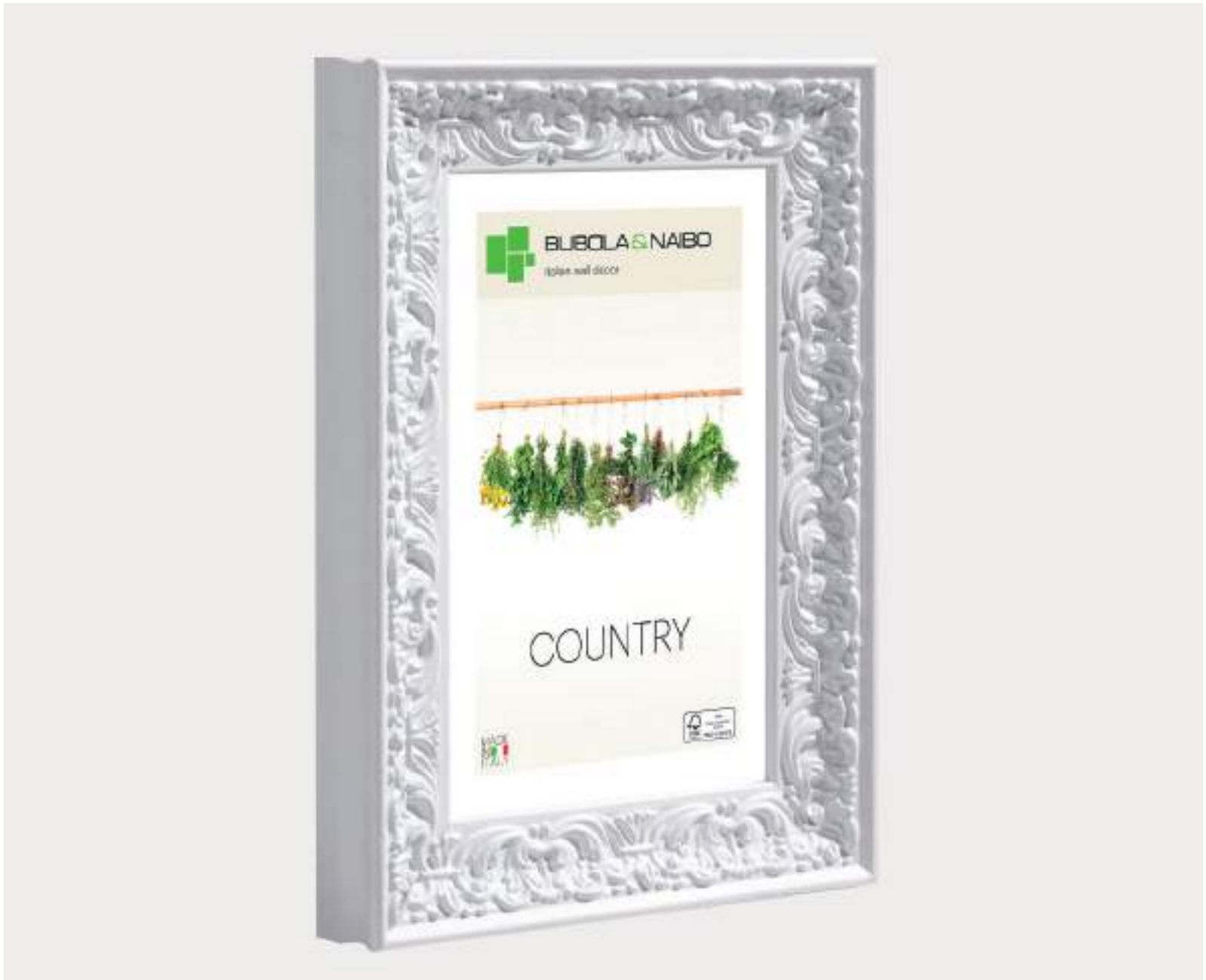
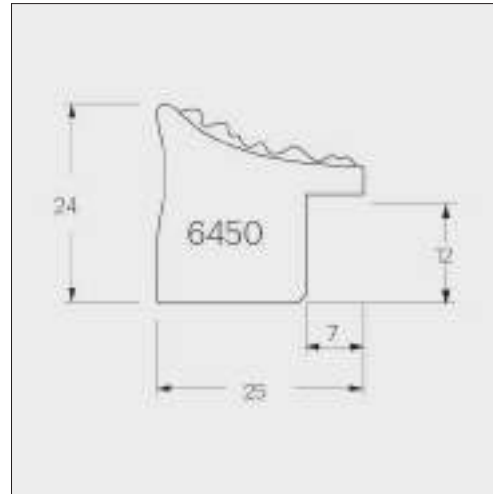

Classic

Sobrietà, eleganza,
tradizione e sapori
antichi, tutto ciò
è racchiuso in una
cornice classic,
un tocco d'eternità.

EN Classic

Sobriety, elegance, tradition and ancient tastes: all this is included in a classical frame, a touch of eternity.

DE Classic

Enthaltbarkeit, Eleganz, Tradition und uralte Geschmäcke, all dies enthält ein klassischer Rahmen: ein Hauch von Ewigkeit.

FR Classic

Sobriété, élégance, traditions et saveurs anciennes; tout ce qui est dans un cadre classique.
Une touche d'éternité.

ES Classic

Sobriedad, elegancia, tradición y sabores antiguos, todo esto está encerrado en un marco classic, un toque de eternidad.







Serie: **Ivanete**

Art.: 6650



			
Size	Min. Q.ty	Size	Min. Q.ty
10x15	2	21x29,7	2
13x18	2	24x30	2
15x20	2	30x40	2
18x24	2	29,7x42	1
		30x45	1
		40x50	1
		50x60	1
		50x70	1
		60x80	1



Cod. Col. 6650/02



Cod. Col. 6650/07

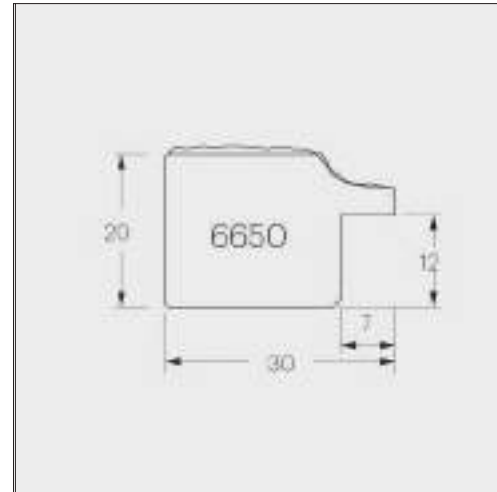



Serie: **Humphrey**

Art.: 3860-3840



			
Size	Min. Q.ty	Size	Min. Q.ty
10x15	2	21x29.7	2
13x18	2	24x30	2
18x24	2	25x35	2
		30x40	2
		30x45	2
		35x50	2
3840			
		40x50	1
		50x60	1
		50x70	1
		60x80	1
		70x100	1



Cod. Col. 3860/14
3840/14

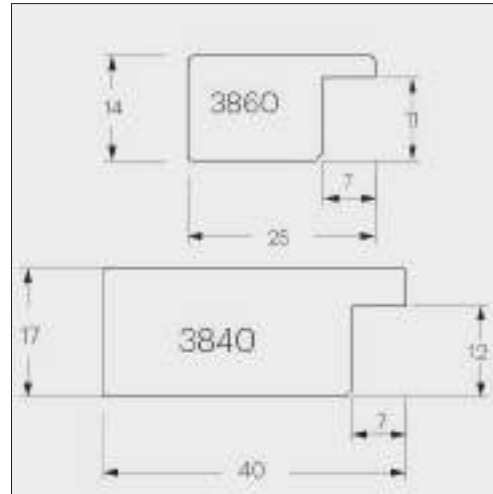

Serie: **Kari**

Art.: 6590



Size	Min. Q.ty	Size	Min. Q.ty
10x15	2	21x29,7	2
13x18	2	24x30	2
15x20	2	25x35	2
18x24	2	29,7x42	2
		30x40	2
		30x45	2
		35x50	2
		40x50	2
		40x60	2
		50x70	2



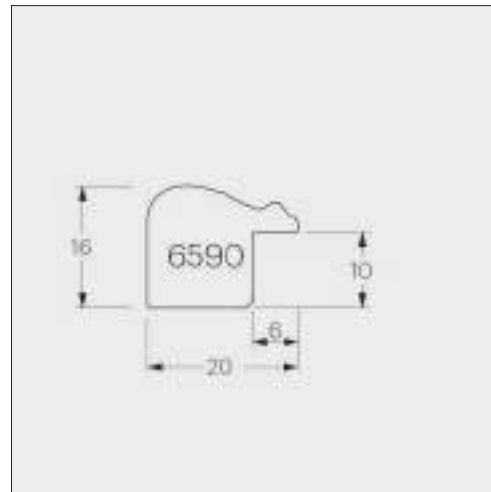

Cod. Col. 6590/01



Serie: **Catherine**

Art.: 4310



			
Size	Min. Qty	Size	Min. Qty
10x15	2	20x30	2
13x18	2	21x29.7	2
18x24	2	24x30	2
		25x35	2
		30x40	2
		35x50	1
		40x50	1
		40x60	1
		50x70	1



Cod. Col. 4310/02



Cod. Col. 4310/01

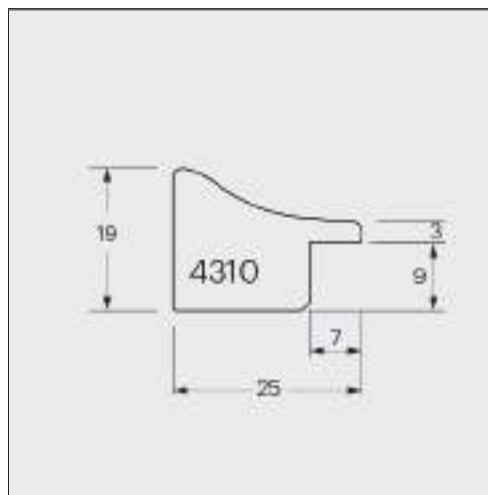

Serie: **Greta**

Art.: 3061



Size		Min. Qty	Size		Min. Qty
10x15		2	20x30		2
13x18		2	21x29.7		2
15x20		2	24x30		2
18x24		2	25x35		2
			29.7x42		2
			30x40		2
			30x45		2
			35x50		2
Size	Ppt Size	Min. Qty			
20x20	14x14	2	40x50		2
30x30	20x20	2	40x60		2
			50x70		2



Cod. Col. 3061/MM

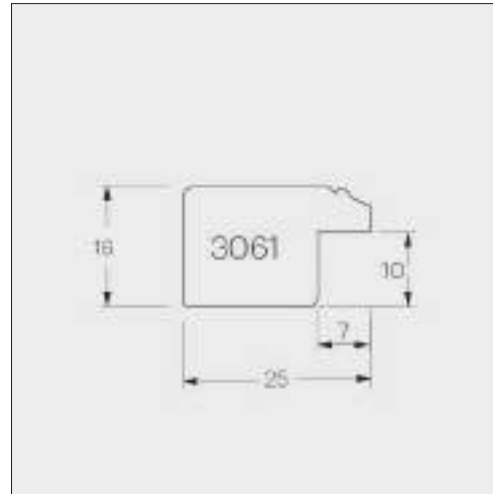



Serie: **Molly**

Art.: OVA



Size	Min. Q.ty	Size	Min. Q.ty
10x15	2	24x30	2
13x18	2	30x40	2
18x24	2		

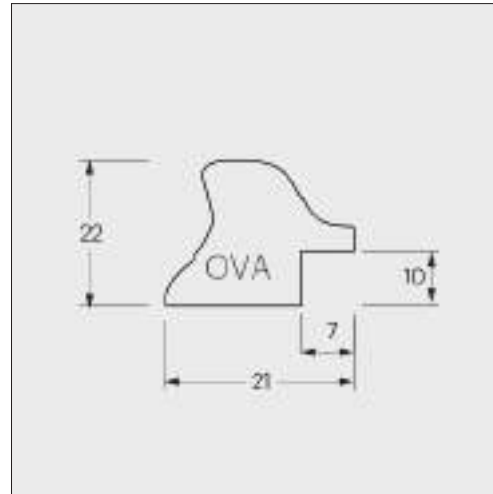

- Cod. Col. OVA/MM
- Cod. Col. OVA/OO
- Cod. Col. OVA/AA
- Cod. Col. OVA/BI



Serie: **Claudia**

Art.: 5000



			
Size	Min. Q.ty	Size	Min. Q.ty
10x15	2	20x30	2
13x18	2	21x29.7	2
15x20	2	24x30	2
18x24	2	25x35	2
		30x40	2
		29.7x42	2
		30x45	2
		35x50	2
		40x50	2
		40x60	2
		50x70	2



Cod. Col. 5000/OO

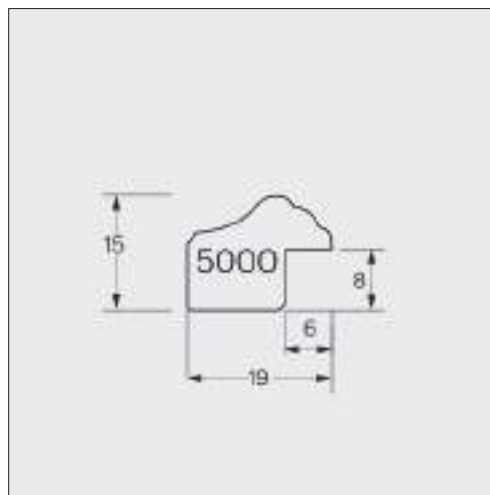

Cod. Col. 5000/AA



Serie: **Claudia**

Art.: 5000



			
Size	Min. Q.ty	Size	Min. Q.ty
10x15	2	20x30	2
13x18	2	21x29.7	2
15x20	2	24x30	2
18x24	2	25x35	2
		30x40	2
		29.7x42	2
		30x45	2
		35x50	2
		40x50	2
		40x60	2
		50x70	2



Cod. Col. 5000/03



Cod. Col. 5000/04

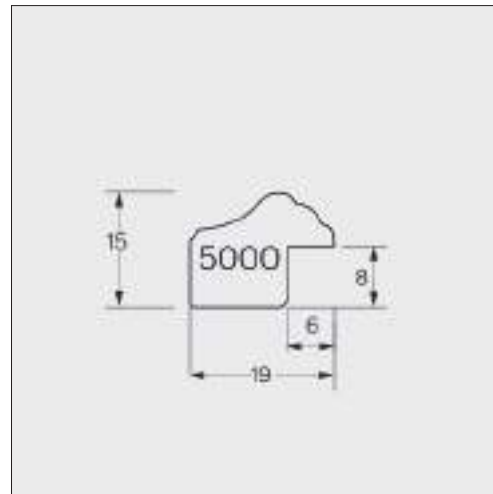

Serie: **Doris**

Art.: P15



Size	Min. Q.ty	Size	Min. Q.ty
10x15	2	20x30	2
13x18	2	21x29.7	2
15x20	2	24x30	2
18x24	2	25x35	2
		30x40	2
		30x45	2
		35x50	2
		40x50	2
		50x70	2



Cod. Col. P15/OO



Cod. Col. P15/NA

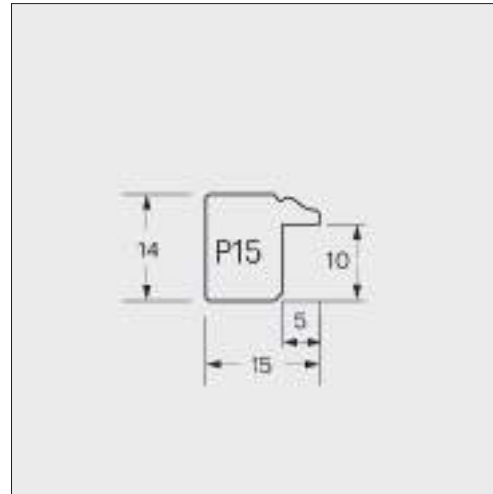

Serie: **Blu**

Art.: BLU



			
Size	Min. Q.ty	Size	Min. Q.ty
10x15	2	20x30	2
13x18	2	21x29.7	2
15x20	2	24x30	2
18x24	2	25x35	2
		30x40	2
		30x45	2
		35x50	2
		40x50	2
		50x70	2



Cod. Col. BLU/04

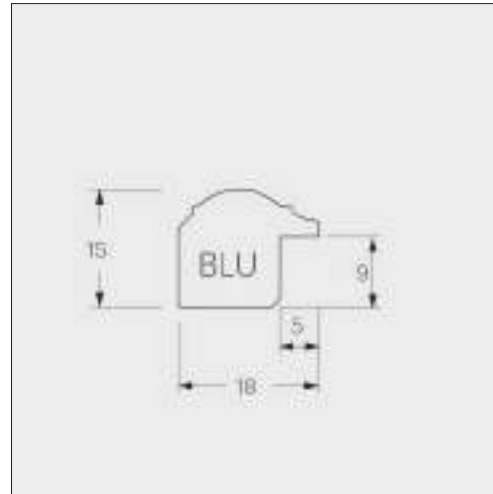

Golden & Silver

I colori del sole e del ghiaccio, freddo e caldo, gli opposti si attraggono e si mescolano negli ambienti moderni come in quelli più classici.

EN Golden & Silver

The colours of the sun and the ones of the ice, cold and hot, the opposites attract themselves and mix together in the modern rooms as well as in the more classical ones.

DE Golden & Silver

Sonnen- und Eisfarben, kalt und heiß, Gegensätze ziehen sich an und mischen sie sich sowohl in den modernen als auch in den klassischeren Räumen.

FR Golden & Silver

Les couleurs du sol et de la glace. Le froid et le chaud. Les opposés s'attirent et se mélangent dans les éléments modernes comme dans les plus classiques.

ES Golden & Silver

Los colores del sol y del hielo, frío y calor, los opuestos se atraen y se mezclan tanto en los ambientes modernos como en los clásicos.







Serie: **Kelly**

Art.: 5980



			
Size	Min. Qty	Size	Min. Qty
10x15	2	20x30	2
13x18	2	21x29.7	2
15x20	2	24x30	2
18x24	2	25x35	2
		30x40	2
		29.7x42	2
		30x45	2
		40x50	2
		50x60	2
		50x70	2



Cod. Col. 5980/12



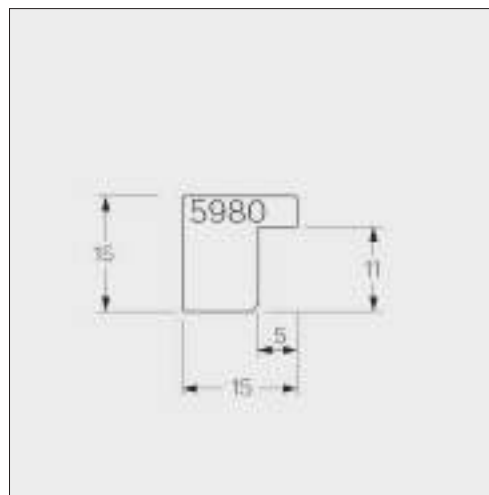

Cod. Col. 5980/14



Serie: **Amalfi**

Art.: 6875



			
Size	Min. Q.ty	Size	Min. Q.ty
10x15	2	21x29,7	2
13x18	2	24x30	2
15x20	2	30x40	2
18x24	2	29,7x42	2
		30x45	2
		40x50	2
		50x60	2
		50x70	2
		60x80	2



Cod. Col. 6875/01



Cod. Col. 6875/02

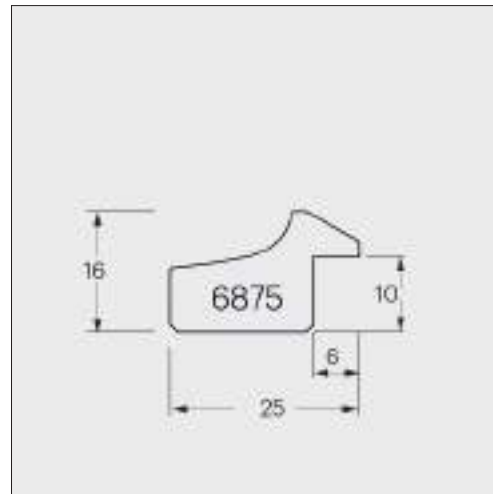

Serie: **Marisa**

Art.: 6280



Size	Min. Q.ty	Size	Min. Q.ty
10x15	2	21x29.7	2
13x18	2	24x30	2
15x20	2	25x35	2
18x24	2	30x40	2
		29,7x42	2
		30x45	2
		35x50	2
		40x50	2
		40x60	2
		50x60	2
		50x70	2



Cod. Col. 6280/01



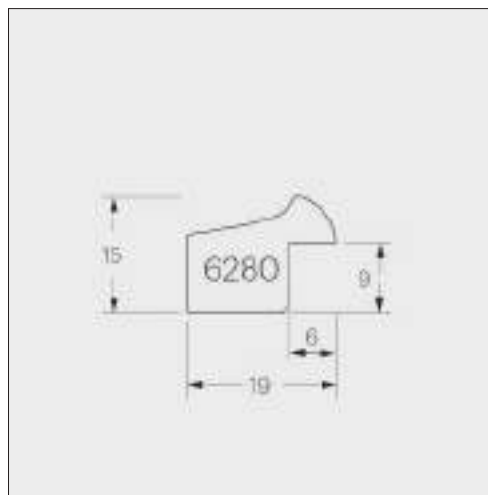

Cod. Col. 6280/02



Serie: **Jenny**

Art.: 4040-4050



			
Size	Min. Q.ty	Size	Min. Q.ty
10x15	2	21x29.7	2
13x18	2	24x30	2
18x24	2	30x40	2
		40x50	2
4050			
		40x50	1
		50x60	1
		50x70	1
		60x80	1



Cod. Col. 4040/AA
4050/AA

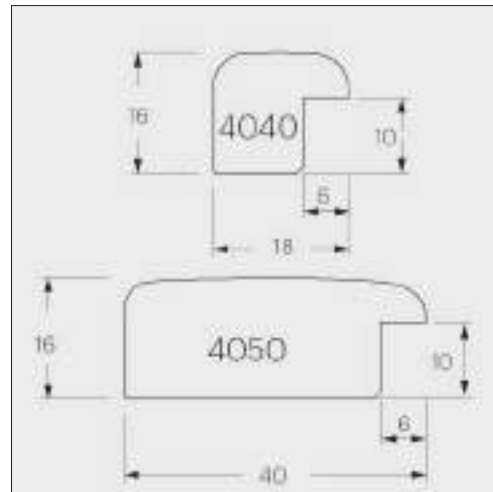

Serie: **Elisabeth**

Art.: 5260-5270



Size		Min. Q.ty	Size		Min. Q.ty
10x15		2	21x29.7		2
13x18		2	24x30		2
18x24		2	25x35		2
			29.7x42		2
			35x50		2
			40x50		1
			50x70		1
Size	PPT Size	Min. Q.Ty	5270		
20x20	14x14	2	40x50		1
30x30	20x20	2	50x60		1
			50x70		1
			60x80		1
			70x100		1



Cod. Col. 5260/AA
5270/AA

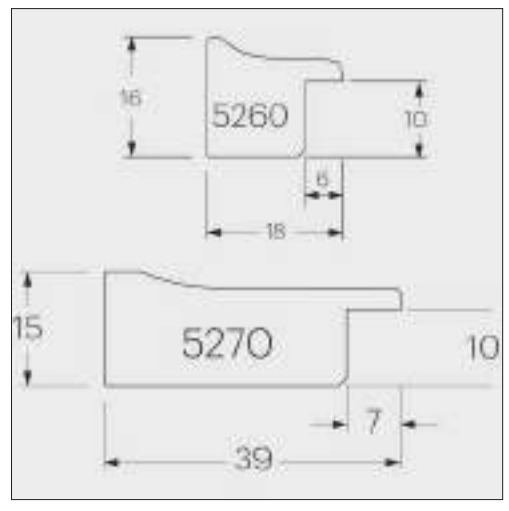

Serie: **Sylvia**

Art.: 5640



Size	Min. Q.ty	Size	Min. Q.ty
10x15	2	21x29.7	2
13x18	2	24x30	2
15x20	2	30x40	2
18x24	2	40x50	1
		50x70	1



Cod. Col. 5640/OO



Cod. Col. 5640/AA

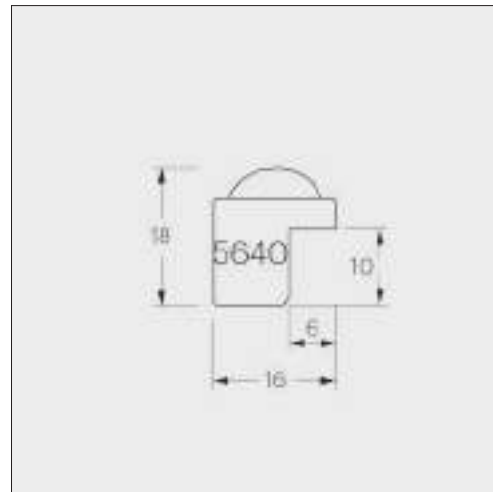

Serie: **Beta**

Art.: 2490



Size	Min. Q.ty	Size	Min. Q.ty
10x15	2	20x30	2
13x18	2	21x29.7	2
15x20	2	24x30	2
18x24	2	25x35	2
		29,7x42	2
		30x40	2
		30x45	2
		35x50	2
		40x50	2
		50x60	2
		50x70	2



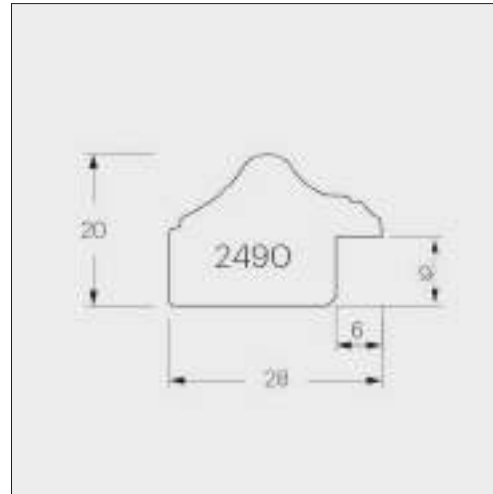

Cod. Col. 2490/OO



Serie: **Smith**

Art.: 5170



			
Size	Min. Q.ty	Size	Min. Q.ty
10x15	2	20x30	2
13x18	2	21x29.7	2
15x20	2	24x30	2
18x24	2	25x35	2
		29,7x42	2
		30x40	2
		30x45	2
		35x50	2
		40x50	2
		50x60	2
		50x70	2



Cod. Col. 5170/01



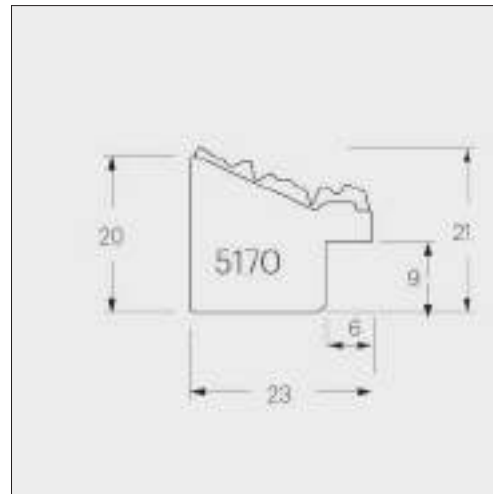

Cod. Col. 5170/07



Serie: Amber

Art.: 6450



			
Size	Min. Q.ty	Size	Min. Q.ty
10x15	2	21x29,7	2
13x18	2	24x30	2
15x20	2	25x35	2
18x24	2	30x40	2
		29,7x42	2
		30x45	2
		35x50	2
		40x50	2
		50x60	2
		50x70	2
		60x80	2



Cod. Col. 6450/OO



Cod. Col. 6450/AA

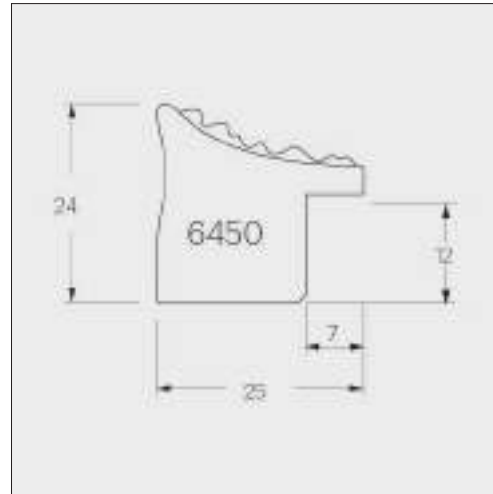

Serie: **Archea**

Art.: 2330



			
Size	Min. Q.ty	Size	Min. Q.ty
10x15	2	21x29,7	2
13x18	2	24x30	2
15x20	2	25x35	2
18x24	2	30x40	2
		29,7x42	2
		30x45	2
		35x50	2
		40x50	2
		50x60	2
		50x70	2



Cod. Col. 2330/OO



Cod. Col. 2330/AA

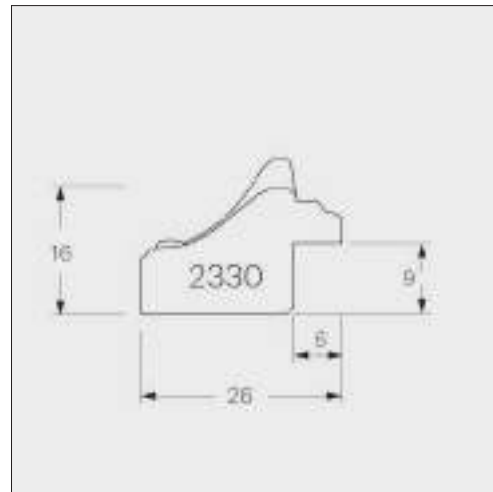

Serie: **Clio**

Art.: 2340



			
Size	Min. Q.ty	Size	Min. Q.ty
10x15	2	20x30	2
13x18	2	24x30	2
15x20	2	30x40	2
18x24	2	29,7x42	2
		30x45	2
		35x50	2
		40x50	2
		50x60	2
		50x70	2
		60x80	2



Cod. Col. 2340/OO

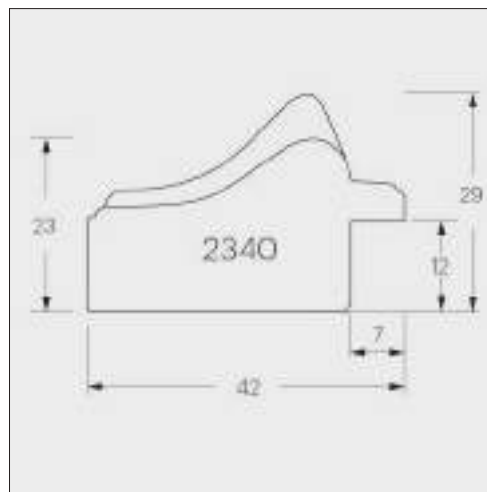

Serie: **JOSS**

Art.: 4000



Size	Min. Q.ty	Size	Min. Q.ty
10x15	2	20x30	2
13x18	2	21x29.7	2
15x20	2	24x30	2
18x24	2	25x35	2
		29,7x42	2
		30x40	2
		30x45	2
		35x50	2
		40x50	1
		50x60	1
		50x70	1
		60x80	1



Cod. Col. 4000/01



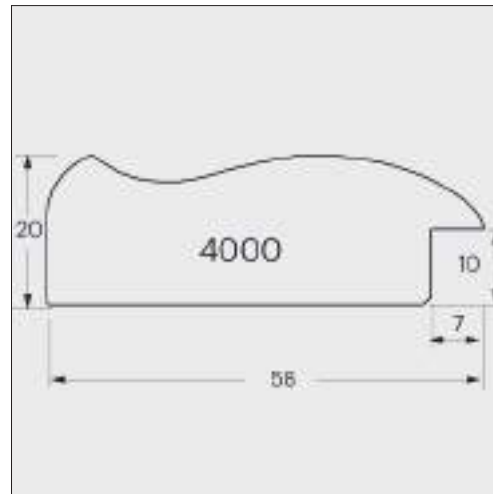

Cod. Col. 4000/07



Serie: **1st Price**

Art.: 999



			
Size	Min. Q.ty	Size	Min. Q.ty
∅ 10x15	5	∅ 20x30	5
∅ 13x18	5	∅ 21x29,7	5
∅ 18x24	5	∅ 24x30	5
		∅ 25x35	5
		∅ 29,7x42	5
		∅ 30x40	5
		∅ 35x45	5
		∅ 40x50	5
		∅ 50x60	5
		∅ 50x70	5
		∅ 60x80	5
		∅ 70x100	5

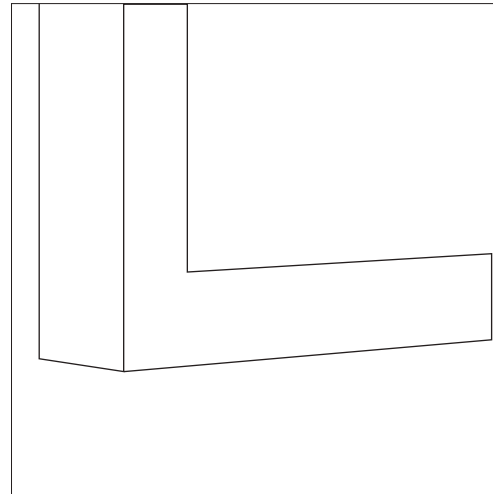



Minimal

Minimal, linee essenziali, concetti puliti, un tratto leggero, l'anima è nelle immagini.

EN Minimal

Minimal, essential lines, clean concepts, a light line. The soul is in the images.

DE Minimal

Minimal, essentielle Linien, klare Konzepte, ein leichter Strich. Die Seele liegt in den Bildern.

FR Minimal

Des lignes essentielles, des concepts propres, un trait doux: l'âme reste dans l'image.

ES Minimal

Minimalista, líneas esenciales, conceptos limpios, un rasgo ligero, el alma está en las imágenes.









Serie: **Alu-Design**

Art.: AL01



Size		Min. Q.ty	
10x15	2	21x29.7	2
13x18	2	24x30	2
15x20	2	30x40	2
18x24	2	29.7x42	2
		40x50	2
		50x70	2
		60x80*	2
		70x100*	2
		PLEXI*	

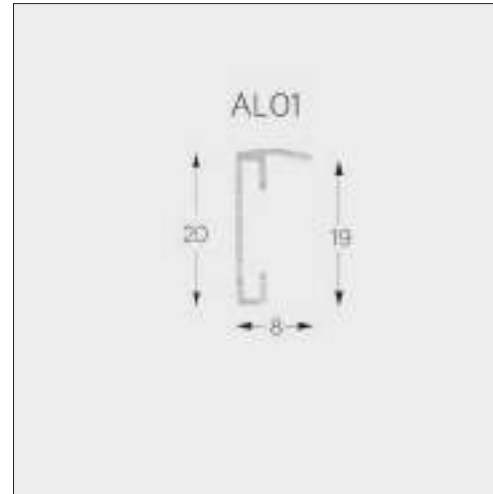

-  Cod. Col. AL01/01
-  Cod. Col. AL01/02
-  Cod. Col. AL01/05
-  Cod. Col. AL01/06



Serie: **Alu-Design**

Art.: AL02



			
Size	Min. Qty	Size	Min. Qty
10x15	2	21x29,7	2
13x18	2	24x30	2
15x20	2	30x40	2
18x24	2	29,7x42	2
		40x50	2
		50x70	2
		60x80	2
		61x91,5	2

-  Cod. Col. AL02/01
-  Cod. Col. AL02/02
-  Cod. Col. AL02/05
-  Cod. Col. AL02/06

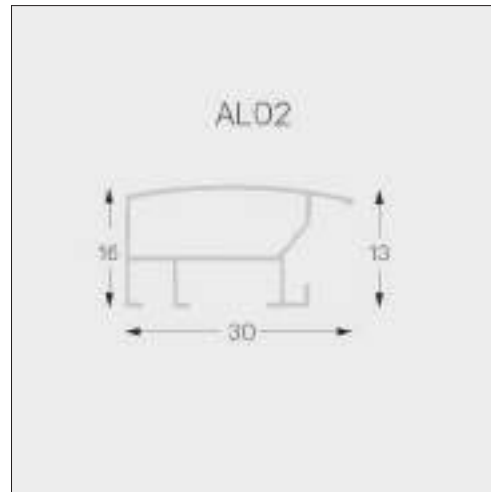

Serie: **Pla-Style**

Art.: PLA01



Size		Min. Qty		Size		Min. Qty	
10x15	5	20x30	5				
13x18	5	21x29,7	5				
15x22	5	24x30	5				
18x24	5	30x40	5				
		30x45	5				
		40x50	2				
		40x60	2				
		50x70	2				
PLEXI		60x80	2				
60x80 CR*	2	61x91,5	2				
70x100 CR*	2	70x100	2				



Cod. Col. PLA01/BI

Cod. Col. PLA01/AA

Cod. Col. PLA01/OO

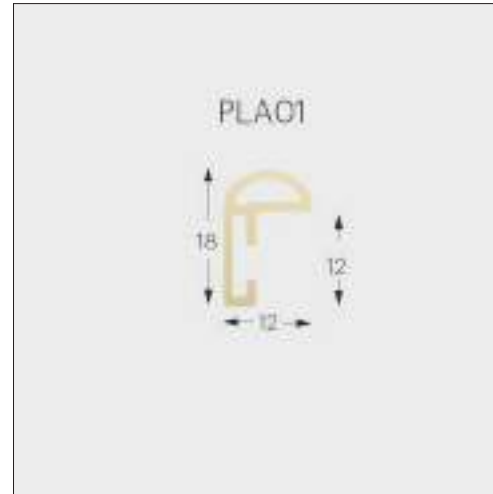



Serie: **Pla-Style**

Art.: PLA01



Size		Min. Q.ty		Size		Min. Q.ty	
10x15	5	20x30	5				
13x18	5	21x29,7	5				
15x22	5	24x30	5				
18x24	5	30x40	5				
		30x45	5				
		40x50	2				
		40x60	2				
		50x70	2				
PLEXI		60x80	2				
60x80 CR*	2	61x91,5	2				
70x100 CR*	2	70x100	2				

-  Cod. Col. PLA01/NE
-  Cod. Col. PLA01/BL
-  Cod. Col. PLA01/RO

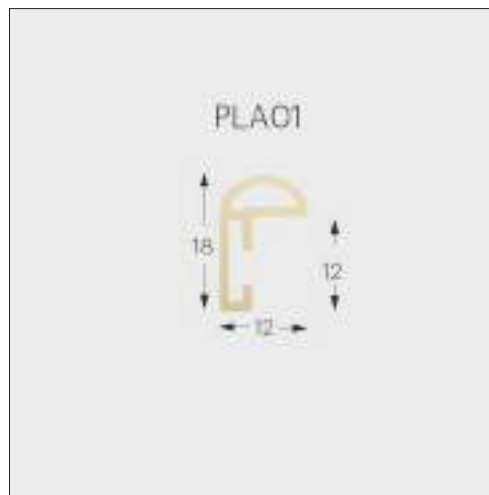

Serie: **Clips**

Art.: GIO



GIO NO Vetro Normale Normal Glass Normalglas Verrre Normal Vidrio Normal				GIO AN Vetro Antiriflesso Antireflex Glass Refloglas Verre Antireflex Vidrio Antireflejo			
Size	Min. Qty	Size	Min. Qty	Size	Min. Qty	Size	Min. Qty
10x15	10	29,7x42	10	13x18	10	50x70	6
13x18	10	30x45	10	18x24	10	60x80	4
15x20	10	35x45	10	20x30	10	61x91,5	4
18x24	10	35x50	10	21x29,7	10	70x100	4
20x20	10	40x50	10	24x30	10		
20x25	10	40x60	6	25x35	10		
20x30	10	50x60	6	30x40	10		
21x29,7	10	50x70	6	29,7x42	10		
24x30	10	60x80	4	30x45	10		
25x35	10	61x91,5	4	35x50	10		
30x30	10	70x100	4	40x50	10		
30x40	10			40x60	6		



Serie: **Plexi Clips**

Art.: GIO



GIO CR Vetro Sintetico Plexiglass Plexiglass			
Size	Min. Q.ty	Size	Min. Q.ty
13x18	10	30x45	10
15x20	10	35x50	10
18x24	10	40x50	10
20x25	10	40x60	6
20x30	10	50x60	6
21x29,7	10	50x70	6
24x30	10	60x80	6
25x35	10	61x91,5	6
30x40	10	70x100	5
29,7x42	10		





Serie: **Clear's**
PCLEAR 01OZ



HORIZONTAL	
SIZE	MIN.Q.TY
10x15	10
13x18	10
15x20	10
20x30	10



PCLEAR 01VT



VERTICAL	
SIZE	MIN.Q.TY
10x15	10
13x18	10
15x20	10
18x24	10
21x29,7	10



PCLEAR 02VT



DOUBLE	
SIZE	MIN.Q.TY
2x 10x15	10
2x 13x18	10





Articoli complementari

- EN Sundry Articles
- DE Zubehoere
- FR Articles Complémentaires
- ES Complementos de Enmarcación

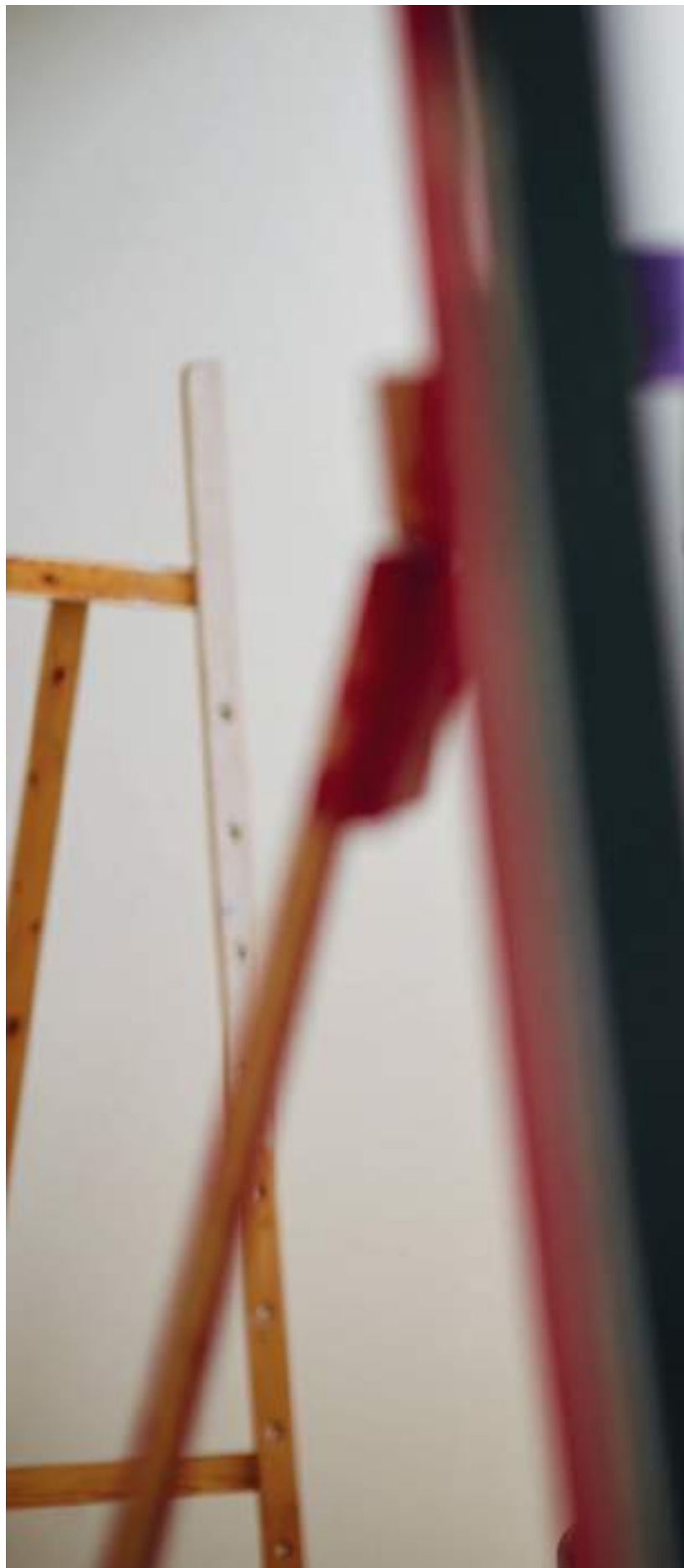



Serie: Belle Arti

Fine art | Schöne Künste
Beaux arts | Bellas artes



PANTE BI

SIZE	MIN.Q.TY
13x18	10
18x24	10
24x30	10
25x35	10
30x40	10
40x50	10

Pannello telato bianco, spessore 3,5mm
Linen canvas white, thickness 3,5mm
Keilrahmen weiss, Dicke 3,5mm
Carton toilé blanche, épaisseur 3,5mm
Panel de lienzo blanco, espesor 3,5mm



TELAIO HT18

SIZE	MIN.Q.TY
13x18	10
20x20	10
20x30	10
24x30	10
25x35	10
30x40	10
30x50	10
35x50	10
40x40	10
40x50	10
40x80	10
50x60	10
50x70	10
50x100	10
60x80	10
70x100	6

Tela da pittore, spessore 18mm, 100% cotone grana media da 280 gr, preparazione universale per colori ad olio, acrilici e tempera, doppia imprimitura.

Linen canvas, thickness 18mm, 100% cotton medium grain, Weight 280 g., double primed, suitable for oils, acrylics and gouache.

Keilrahmen, Dicke 18mm, 100% Baumwolle, mittelgroß Gewicht 280 g., zweifach universalgrundiert, für Öl, Akryl, Gouache.

Châssis épaisseur 18mm, 100% coton grain moyen poids 280g, enduction universelle en 2 couches pour peinture à l'huile, acrylique et gouache.

Lienzo de pintor, espesor 18mm, 100% de algodón de grano medio peso 280g, preparacion universal para colores al oleo, acrilico y pintura al temple.



TELAIO HT35

SIZE	MIN.Q.TY
20x20	5
20x30	5
25x35	5
30x30	5
35x50	5
30x60	5
40x40	5
20x60	5
30x90	5
40x80	5
40x120	5
50x100	5

Tela da pittore, spessore 35mm, 100% cotone grana media da 280 gr, preparazione universale per colori ad olio, acrilici e tempera, doppia imprimitura.

Linen canvas, thickness 35mm, 100% cotton medium grain, Weight 280 g., double primed, suitable for oils, acrylics and gouache.

Keilrahmen, Dicke 35mm, 100% Baumwolle, mittelgroß Gewicht 280 g., zweifach universalgrundiert, für Öl, Akryl, Gouache.

Châssis épaisseur 35mm, 100% coton grain moyen poids 280g, enduction universelle en 2 couches pour peinture à l'huile, acrylique et gouache.

Lienzo de pintor, espesor 35mm, 100% de algodón de grano medio peso 280g, preparacion universal para colores al oleo, acrilico y pintura al temple.



Serie: **Tamara** Art. 4260V

Empty frames | Leerrahmen
Cadres vides | Marcos vacios



SIZE	MIN. Q.TY	SIZE	MIN. Q.TY
13x18	1	40x40	1
18x24	1	40x50	1
20x20	1	40x60	1
20x30	1	40x80	1
24x30	1	50x60	1
25x35	1	50x70	1
30x40	1	50x100	1
30x45	1	60x80	1
35x50	1	70x100	1



Cod. Col. 4260V/05



Cod. Col. 4260V/04



Cod. Col. 4260V/03



Cod. Col. 4260V/02



Cod. Col. 4260V/01

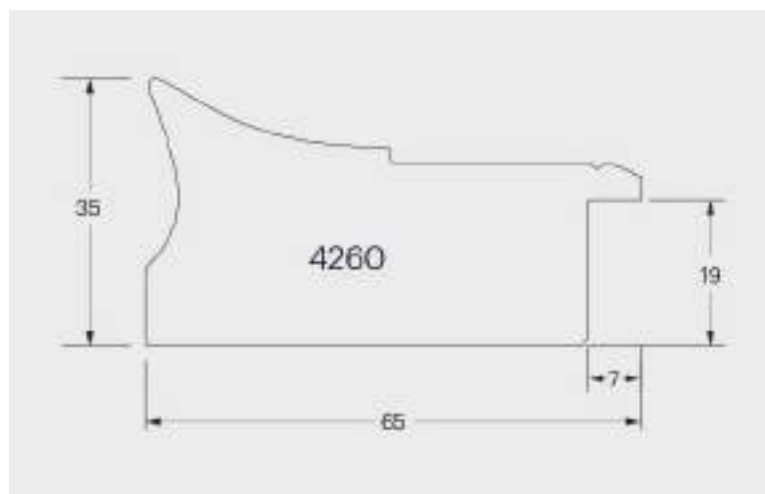

Serie: **Belle Arti**

Fine art | Schöne Künste
Beaux arts | Bellas artes



Cavalletti pieghevoli in faggio, varie misure
Folding leg easels of beech-wood, various sizes
Klapptischstaffeleien aus Buchenholz, verschiedene Größe
Chevalets pliants en hêtre, différentes mesures
Caballetes flexibles de haya, diferentes medidas
Min. qty: 2



h 30cm

CALE NA C01
Max canvas size: 20 cm



h 50cm

CALE NA C02
Max canvas size: 40 cm



h 90cm

CALE NA C03
Max canvas size: 65 cm



h 150cm

CALE NA C04
Max canvas size: 120 cm



h 170-235cm

CALE NA C06
Max canvas size: 130 cm



Serie: **Belle Arti**

Fine art | Schöne Künste
Beaux arts | Bellas artes



Cavalletti pieghevoli in faggio, varie misure
Folding leg easels of beech-wood, various sizes
Klapptischstaffeleien aus Buchenholz, verschiedene Größe
Chevalets pliants en hêtre, différentes mesures
Caballetes flexibles de haya, diferentes medidas
Min. qty: 2



CALE NA C07
Max canvas size: 105 cm

h 185cm



CALE NA C09
Max canvas size: 120 cm

h 171-237cm



Serie: Passepartout

PASSEPARTOUT - Packaging 5

Passepartout a smusso pretagliati e imballati singolarmente, spessore 1,3 mm
 Pre-cut mountboards, single packed, thickness 1,3 mm
 Schrägschnitt Passepartout vorgeschritten und einzeln verpackt, Dicke 1,3 mm
 Contre-collé PPT biseauté, emballé individuellement, épaisseur 1,3 mm
 Passepartout redondeado precortado y embalados individual, esp. 1,3 mm

CASMUS AV - (1005)



CASMUS BI - (1012)



CASMUS RO - (1006)

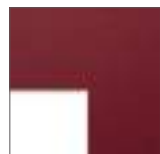

CASMUS BG - (1030)



CASMUS BL - (1008)

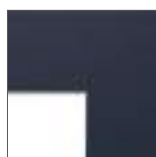

CASMUS VE - (1007)



CASMUS NE - (1009)



CASMUS MM - (1022)



EXT	INT	MIN.Q.TY
10x15	7x10	5
13x18	9x13	5
18x24	10x15	5
20x30	13x18	5
21x29,7	13x18	5
24x30	15x20	5
30x40	20x30	5
40x50	30x40	5
50x60	40x50	5
50x70	30x45	5
60x80	40x60	5

CASMUG AV - (1005)

Passepartout a smusso pretagliati e imballati singolarmente, spessore 2,6mm
 Pre-cut mountboards, single packed, thickness 2,6mm
 Schrägschnitt Passepartout vorgeschritten und einzeln verpackt, Dicke 2,6mm
 Contre-collé PPT biseauté, emballé individuellement, épaisseur 2,6mm
 Passepartout redondeado precortado y embalados individual, esp. 2,6mm

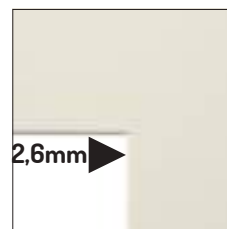

EXT	INT	MIN.Q.TY
30x40	20x30	5
40x50	30x40	5
50x60	40x50	5
50x70	30x45	5
60x80	50x70	5

ESPO PPT3

EXT	INT	MIN.Q.TY
10x15	7x10	30
13x18	9x13	30
18x24	10x15	30
20x30	13x18	15
21x29,7	13x18	15
24x30	15x20	30
30x40	20x30	30



ESPO PPT

EXT	INT	MIN.Q.TY
10x15	7x10	5
13x18	9x13	5
18x24	10x15	5
20x30	13x18	5
21x29,7	13x18	5
24x30	15x20	5
30x40	20x30	5
40x50	30x40	5





Serie: Passepartout

PASSEPARTOUT - 80x120cm ACID FREE, WHITE CORE - Packaging 5

CARTW 1004
OFF WHITE



CARTW 1005
SOFT WHITE

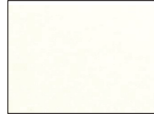

CARTW 1011
BISQUIT

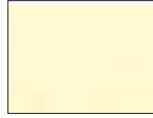

CARTW 1012
ULTRA WHITE



CARTW 1013
PORCELAIN

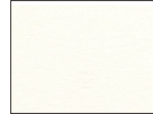

CARTW 1014
CHAMOIS



CARTW 1016
BRICK



CARTW 1017
LIGHT RED



CARTW 1018
RED



CARTW 1022
DARK BROWN

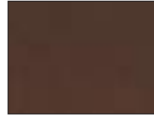

CARTW 1024
DELFT

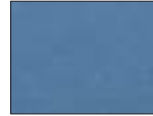

CARTW 1025
CAPE COD



CARTW 1026
PEARL



CARTW 1029
CHARCOAL



CARTW 1030
BUFF



CARTW 1006
LAUB

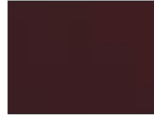

CARTW 1007
FOREST GREEN



CARTW 1008
INDIGO



CARTW 1009
BLACK

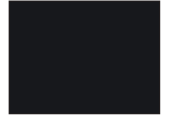

BACKING BOARDS



CAR O2 - Packaging 20

Cartone ondulato per retri cm 100x140, sp. 4,5 mm
Corrugated backing board cm 100x140, 4,5 mm thick
Wellpappe für Rückwand 100x140cm, Dicke 4,5 mm
Carton ondulé pour dos de cadre 100x140, épaisseur 4,5 mm
Cartón ondulado para traseras cm 100x140, esp. 4,5 mm



CAR PBS1 - Packaging 20

Cartone per retri autoadesivo cm 80x120, sp. 1,5 mm
Self Adhesive pulp board cm 80x120, 1,5 mm thick
Selbstklebend Karton für Rückwand 80x120cm, Dicke 1,5 mm
Carton autocollant pour dos de cadre 80x120, épaisseur 1,5 mm
Cartón para traseras autoadhesivo cm 80x120, esp.1,5 mm

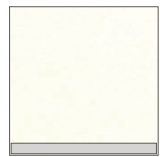

CAR BGW - Packaging 20

Cartone per retri bianco cm 80x120, sp. 2,2 mm
White Liner board cm 80x120, 2,2 mm thick
Karton für Rückwand weiss 80x120cm, Dicke 2,2 mm
Carton blanc pour dos de cadre 80x120, épaisseur 2,2 mm
Cartón para traseras cm 80x120, esp. 2,2cm

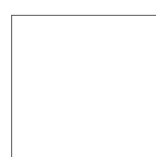

CAR WB2 - Packaging 20

Cartone per retri acid free cm 80x120, sp. 2,4 mm
Acid free board cm 80x120, 2,4 mm thick
Acid free Karton für Rückwand 80x120 cm, Dicke 2,4mm
Carton sans acide pour dos de cadre 80x120, épaisseur 2,4 mm
Cartón para traseras acid free cm 80x120, esp.2,4 mm

RPFRS NE

Retro portafoto in MDF con cerniera scorrevole
MDF back for photoframes with sliding hinge
Rückwand besteht aus MDF und ist mit einem Schiebeaufsteller versehen
Dos de cadre en MDF avec pied amovible
Trasera en MDF con sistema corredizo

SIZE	S.CODE	MIN.Q.TY
10x15	03	10
13x18	04	10
15x20	05	10
18x24	06	10
20x30	08	10
21x29,7	MA4	10



RECEP

Retro portafoto in cartone per cornici fino a 2,5 cm di spessore
Carton back for the photoframes with a moulding of till 2,5 cm of width
Rückwand aus Karton für die Fotorahmen mit einer Leistenbreite bis zu 2,5 cm
Dos de cadre en carton pour cadres d'une largeur maximale de 2,5 cm
Trasera portafoto en carton para marcos hasta 2,5 cm de anchura

SIZE	S.CODE	MIN.Q.TY
10x15	03	10
13x18	04	10
15x20	05	10
18x24	06	10
20x30	08	10
21x29,7	MA4	10



CAR WOOD

Cartone di legno spessore 3 mm
Wooden carton 3 mm thick
Holzrückwand, Dicke 3mm
Carton bois épaisseur 3 mm
Carton de madera 3 mm de grueso

SIZE	S.CODE	MIN.Q.TY
21x29,7	MA4	10
24x30	09	10
30x40	11	10
29,7x42	MA3	10
40x50	17	10
50x70	21	10
60x80	23	10
70x100	26	10





Serie: Attaccaglie

ATTSC packaging: 5

ATTSC-0001 pcs. 10	ATTSC-0002 pcs.5	ATTSC-0003 pcs. 10	ATTSC-0004 pcs. 10	ATTSC-0005 pcs. 5	ATTSC-0006 pcs. 5
ATTSC-0007 pcs. 10	ATTSC-0008 pcs. 10	ATTSC-0009 pcs. 10	ATTSC-0010 pcs. 10	ATTSC-0011 pcs. 10	ATTSC-0012 pcs. 10
ATTSC-0021 1 SET	ATTSC-0022 pcs. 2	ATTSC-0023 pcs. 8	ATTSC-0024 pcs. 2	ATTSC-0025 pcs. 6	ATTSC-0026 pcs. 10
ATTSC-0027 pcs. 10	ATTSC-0028 pcs. 8	ATTSC-0029 pcs. 6	ATTSC-0030 pcs. 10	ATTSC-0031 pcs. 8	ATTSC-0032 pcs. 6

PPG



Appoggio da tavolo in acciaio
Steel table stand
Bildständer aus Stahl
Appui de table en acier
Apoyo de acero para mesa

packaging: 10

SUPP PT

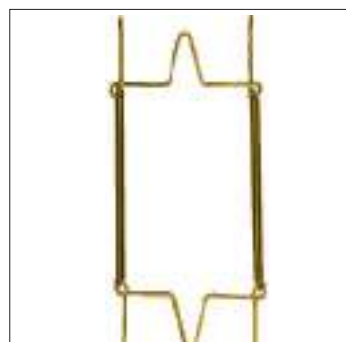

Porta piatti
Plate hooks
Teller aufgehänger
Porte assiettes
Cuelga platos

SUPP PT 01 15-20cm
SUPP PT 02 20-30cm
SUPP PT 03 25-35cm

packaging: 10

ESPO AT01



Serie: **Specchi**

Mirrors
Spiegel
Miroirs
Espejos



Riflesso

Riflesso è uno specchio in vetro adatto a qualsiasi ambiente.
 Riflesso is a mirror in glass, thought for every kind of location.
 Riflesso ist ein Spiegel aus Glas, der für alle Räume gedacht ist.
 Riflesso est un miroir en verre adapté à tout lieu.
 Riflesso es un espejo en vidrio adaptado a cualquier ambiente.



15x15 cm
2 pcs
SPE ST01 15X

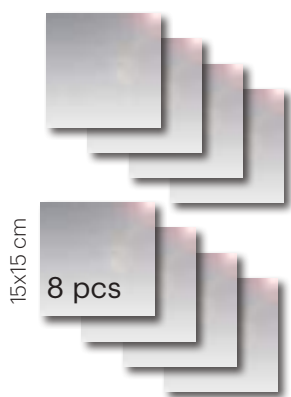

15x15 cm
8 pcs
SPE ST02 15X



40x60 cm
1 pc
SPE NOIM4060



39x130 cm
1 pc
SPE NOIM39D0



29x160 cm
1 pc
SPE NOIM29G0

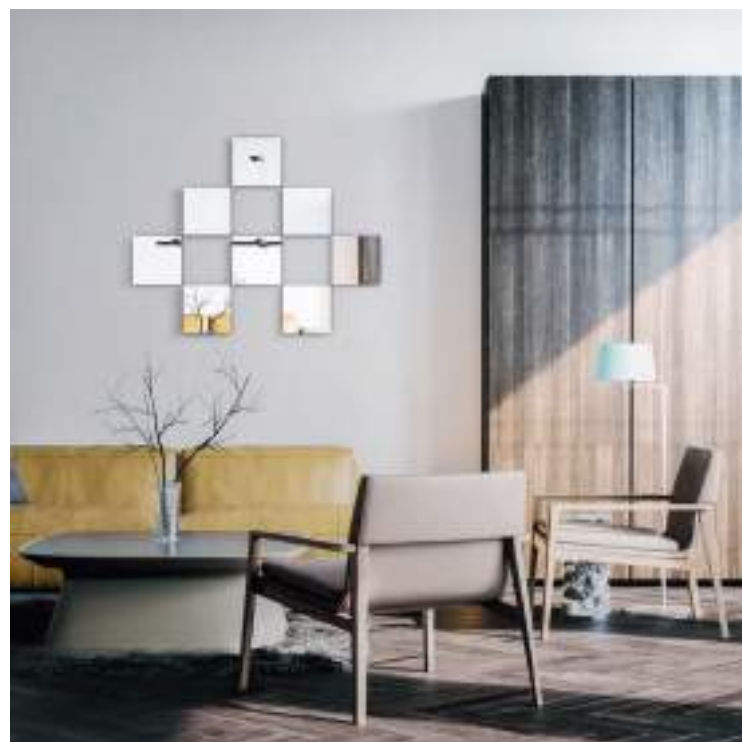

Serie: Memo



CPAN LVBI

Lavagna bianca
White board
Weisse Tafel
Tableau blanc
Pizarra blanca

SIZE	MIN.QTY
30x40	20
40x60	10
60x90	10



CPAN LVSG

Lavagna bianca + pannello di sughero
White board + cork panel
Weisse Tafel + Korktafel
Tableau blanc + tableau en liège
Pizarra blanca + panel de corcho

SIZE	MIN.QTY
40x60	10
60x90	10



CPAN MKBI

Lavagna magnetica bianca
White magnetic board
Weisse Magnettafel
Tableau aimanté blanc
Pizarra magnética blanca

SIZE	MIN.QTY
30x40	20
40x60	10
60x90	10



Serie: Memo



CPAN SG

Pannello di sughero
Cork panel
Korktafel
Tableau en liège
Panel de corcho

SIZE	MIN.QTY
30x40	20
40x60	10
60x90	10



CPANAL MKBI

Lavagna magnetica bianca
White magnetic board
Weisse Magnettafel
Tableau aimanté blanc
Pizarra magnética blanca

SIZE	MIN.QTY
60x90	10

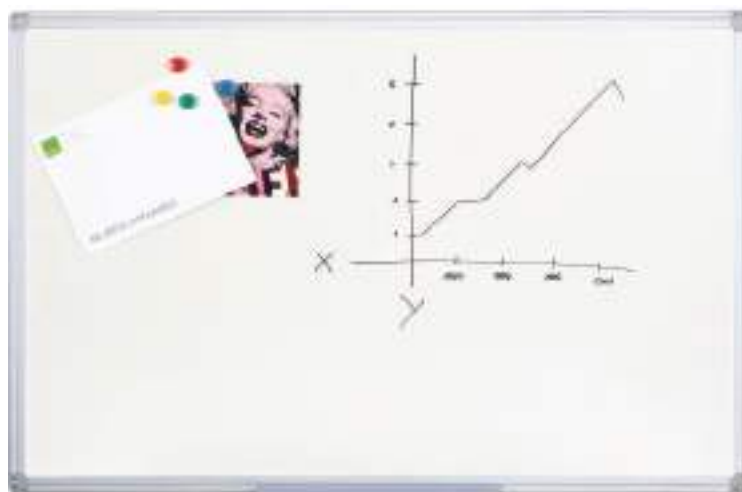

CPAN LVNE

Lavagna nera
Blackboard
Schwarze Tafel
Tableau noir
Pizarra negra

SIZE	MIN.QTY
30x40	11
40x60	18
60x90	24





Serie: Vetri, Faesiti, Specchi

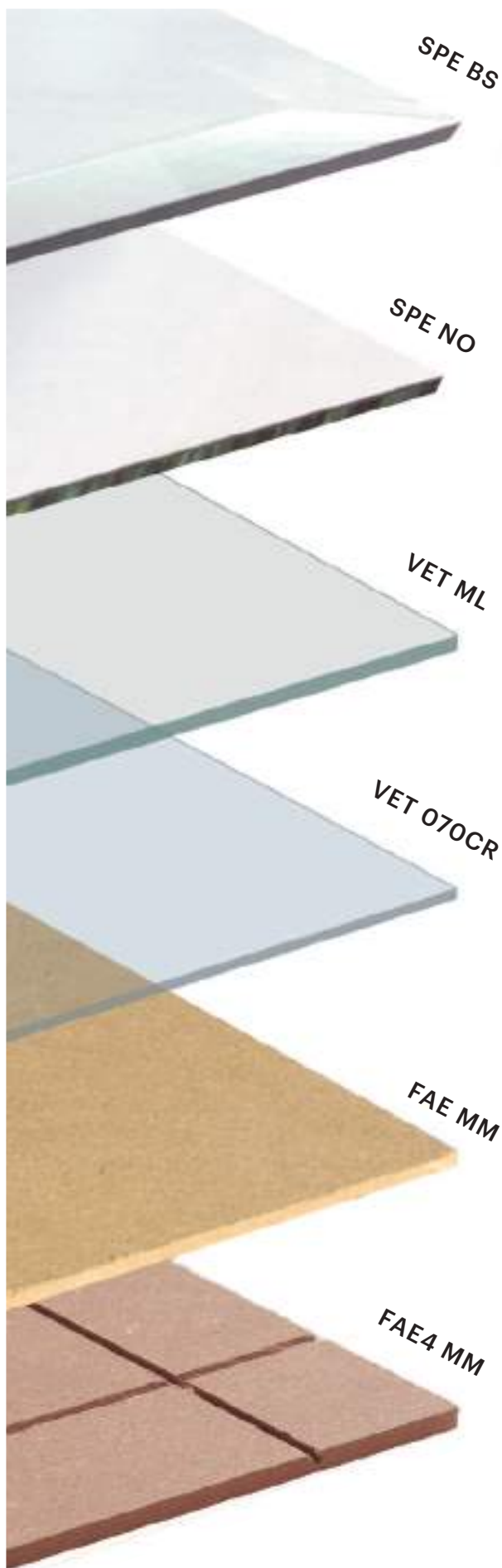

SPE NO-BS

Specchio 3 mm - 4 mm bisellato
3 mm normal mirror - 4 mm bevelled mirror
3 mm Standard-Spiegel - 4 mm Facettenschliff
Miroir 3 mm - 4 mm biseauté
Espejo 3 mm -4 mm biselado

SIZE	MIN.Q.TY
35x50	5
40x50	5
40x60	5
30x90	5
50x70	5
60x80	5
50x100	5
40x120	5
30x130	5
70x100	5

VET 07O CR

Plexiglass da 0,70 mm
0,70 mm Plexiglass
0,70 mm Plexiglas
0,70 mm Plexiglas
0,70 mm Plexiglàs

SIZE	MIN.Q.TY
13x18	10
18x24	10
20x30	10
21x29,7	10
24x30	10
25x35	10
30x40	10
29,7x42	10
35x50	10
40x50	10
50x60	10
50x70	10
60x80	10
70x100	10

VET ML

Vetro normale Molato 2 mm
2 mm normal polished glass
2 mm kantengeschliffenes Glas
Verre normal meulé 2 mm
Cristal normal pulido 2 mm

SIZE	MIN.Q.TY
13x18	10
18x24	10
20x30	10
21x29,7	10
24x30	10
25x35	10
30x40	10
29,7x42	10
35x50	10
40x50	10
50x60	10
50x70	10

FAE MM

MDF 2,5 mm sezionato
2,5 mm cut to size MDF
2,5 mm zugeschnittene MDF - Platte
MDF 2,5 mm coupé
MDF 2,5 mm aserrado

SIZE	MIN.Q.TY
13x18	10
18x24	10
20x30	10
21x29,7	10
24x30	10
25x35	10
30x40	10
29,7x42	10
35x50	10
40x50	10
50x60	10
50x70	10

FAE4 MM

MDF 4 mm sezionato con fresata
4 mm MDF for clip frame
4 mm MDF Platte für Rahmenlose BH
MDF 4 mm pour sous verres
MDF 4 mm para marco clip

SIZE	MIN.Q.TY
13x18	10
18x24	10
20x30	10
21x29,7	10
24x30	10
25x35	10
30x40	10
29,7x42	10
35x50	10
40x50	10
50x60	10
50x70	10
60x80	10
70x100	10



Serie: **Carta gigliata**

Varese Paper.
Dekoratives Pergamentpapier.
Papier de lys.
Passepartouts Papel de lirio.



CAR GL 120 - h. 120cm, l. 200 mt



CAR GL - h. 100cm, l. 200 mt

Serie: **Tela per passepartout**

Linen canvas for passepartouts.
Leinwand für Passepartouts.
Toile pour passe-partout.
Lienzo para passepartout.



TEL BI PPT - h. 150cm, l. 25 mt



TEL PA PPT - h. 150cm, l. 25 mt

Serie: **Indice**Index
Inhaltverzeichnis
Index
Índice**CORNICI - PICTURE FRAMES - BILDERRAHMEN - CADRES - MARCOS**

ART.	SERIE	PAG.	STYLE
12	FRANK	20	DESIGN
13	EVA	36	NATURAL
2330	ARCHEA	79	GOLDEN & SILVER
2340	CLIO	80	GOLDEN & SILVER
2490	BETA	76	GOLDEN & SILVER
2701	GIULIA	37	NATURAL
3061	GRETA	61	CLASSIC
3840 10/11/12	ANDY	43	COLORS
3840 14	HUMPHREY	58	CLASSIC
3860 10/11/12	ANDY	43	COLORS
3860 14	HUMPHREY	58	CLASSIC
4000	JOSS	81	GOLDEN & SILVER
4040 01	JAMES	31	NATURAL
4040 AA	JENNY	73	GOLDEN & SILVER
4050 AA	JENNY	73	GOLDEN & SILVER
4260V	TAMARA	97	EMPTY FRAMES
4310	CATHERINE	60	CLASSIC
4400	POLLY	39	NATURAL
4405	BROOKE	38	NATURAL
4600	RAIA	51	COUNTRY
5000	CLAUDIA	64 - 65	CLASSIC
5015	FABRIANO	50	COUNTRY
5170	SMITH	77	GOLDEN & SILVER
5260 AA	ELISABETH	74	GOLDEN & SILVER
5260 07/14/16/20	VINCE	44	COLORS
5270 AA	ELISABETH	74	GOLDEN & SILVER
5640	SYLVIA	75	GOLDEN & SILVER
5780	NATHALIE	21	DESIGN
5790	MILTON	52	COUNTRY
5810	LELA	18	DESIGN

ART.	SERIE	PAG.	STYLE
5980	KELLY	70	GOLDEN & SILVER
6110	SANDRA	32 - 33	NATURAL
6280	MARISA	72	GOLDEN & SILVER
6310	MARISOL	45	COLORS
6340	TULIPA	30	NATURAL
6370	MARIE CLAIRE	35	NATURAL
6440	CARINA	28 - 29	NATURAL
6450 02	AMBER	53	COUNTRY
6450 AA/OO	AMBER	78	GOLDEN & SILVER
6550	SOLEDAD	49	COUNTRY
6570	DUNE	14	DESIGN
6581	ATHINA	48	COUNTRY
6585	SVEA	16 - 17	DESIGN
6590	KARI	59	CLASSIC
6650	IVANETE	56	CLASSIC
6775	RUDEN	15	DESIGN
6790	UNIKA	23	DESIGN
6860	TOSCA	26 - 27	NATURAL
6875	AMALFI	71	GOLDEN & SILVER
6890	VERA	42	COLORS
999	1ST PRICE	82	1ST PRICE
AL01	ALU-DESIGN	86	MINIMAL
AL02	ALU-DESIGN	87	MINIMAL
BLU	BLU	67	CLASSIC
GIO	CLIPS	90 - 91	MINIMAL
OVA	MOLLY	63	CLASSIC
P15	DORIS	66	CLASSIC
PCLEAR	CLEAR'S	92	MINIMAL
PLA01	PLA-STYLE	88 - 89	MINIMAL

ARTICOLI COMPLEMENTARI - SUNDRY ARTICLES - ZUBEHOERE - ARTICLES COMPLÉMENTAIRES - COMPLEMENTOS DE ENMARCACIÓN

ART.	PAG.
ATTSC	102
CALE NA	98 - 99
CAR 02	101
CAR BGW	101
CAR GL / CAR GL 120	107
CAR PBS1	101
CAR WB2	101
CAR WOOD	101
CARTW	101

ART.	PAG.
CASMUG	100
CASMUS	100
CPAN	104 - 105
ESPO AT01	102
ESPO PPT / ESPO PPT 3	100
FAE / FAE4	106
PANTE BI	96
PPG	102
RECEP	101

ART.	PAG.
RPFRS NE	101
SPE NO / BS	106
SPE ST / NOIM	103
SUPP PT	102
TEL BI PPT / TEL PA PPT	107
TELAIO HT18	96
TELAIO HT35	96
VET ML / 070CR	106

BUBOLA & NAIBO S.r.l.

Via della Lira, 617
31053 Pieve di Soligo (TV) Italy
bubolaenaibo@bubolaenaibo.com
www.bubolaenaibo.com

Contact:

Tel.	+39 0438 9065
Fax.	+39 0438 906694
Uff. Vendite Italia	+39 0438 906650
Export Dept.	+39 0438 906640

Richiedi prodotti certificati FSC®



Italian Wall Decor
bubolaenaibo.com

